

HEAT SOURCE UNITS

1. SPECIFICATIONS	2 - 424
2. EXTERNAL DIMENSIONS	2 - 431
3. CENTER OF GRAVITY	2 - 433
4. ELECTRICAL WIRING DIAGRAMS	2 - 434
5. SOUND LEVELS	2 - 435
6. CAPACITY TABLES	2 - 437
6-1. Correction by temperature	2 - 437
6-2. Correction by total indoor	2 - 445
6-3. Correction by refrigerant piping length	2 - 449
6-4. Correction by port counts of the BC controller	2 - 450
6-5. Operation temperature range	2 - 451
7. SYSTEM DESIGN GUIDE	2 - 452
7-1. Designing of water circuit system	2 - 452
7-2. Water piping work	2 - 464
8. OPTIONAL PARTS	2 - 466
8-1. JOINT	2 - 466
8-2. OUTDOOR TWINNING KIT	2 - 467
8-3. JOINT KIT "CMY-R160-J1" FOR BC CONTROLLER	2 - 468

1. SPECIFICATIONS

G10 2nd

Model			PQRY-P200YHM-A	PQRY-P250YHM-A	
Power source			3-phase 4-wire 380-400-415V 50/60Hz		
Cooling capacity (Nominal)	*1	kW	22.4	28.0	
	*1	kcal / h	19,300	24,100	
	*1	BTU / h	76,400	95,500	
		Power input	kW	3.96	5.51
		Current input	A	6.6-6.3-6.1	9.3-8.8-8.5
	EER	kW / kW	5.65	5.08	
Temp. range of cooling	Indoor	W.B.	15.0 ~ 24.0°C(59 ~ 75°F)		
	Circulating water	°C	10.0 ~ 45.0°C(50 ~ 113°F)		
Heating capacity (Nominal)	*2	kW	25.0	31.5	
	*2	kcal / h	21,500	27,100	
	*2	BTU / h	85,300	107,500	
		Power input	kW	4.12	5.80
		Current input	A	6.9-6.6-6.3	9.7-9.3-8.9
	COP	kW / kW	6.06	5.43	
Temp. range of heating	Indoor	D.B.	15.0 ~ 27.0°C(59 ~ 81°F)		
	Circulating water	°C	10.0 ~ 45.0°C(50 ~ 113°F)		
Indoor unit connectable	Total capacity		50 ~ 150 % of heat source unit capacity		
	Model / Quantity		P15 ~ P250 / 1 ~ 20		
Sound pressure level (measured in anechoic room)		dB <A>	47	49	
Refrigerant piping diameter	High pressure	mm (in.)	15.88(5/8) Brazed	19.05(3/4) Brazed	
	Low pressure	mm (in.)	19.05(3/4) Brazed	22.2(7/8) Brazed	
Circulating water	Water flow rate	m ³ / h	5.76	5.76	
		L / min	96	96	
		cfm	3.4	3.4	
	Pressure drop	kPa	17	17	
	Operating volume range	m ³ / h	4.5 ~ 7.2	4.5 ~ 7.2	
Compressor	Type x Quantity		Inverter scroll hermetic compressor		
	Manufacture		AC&R Works, MITSUBISHI ELECTRIC CORPORATION	AC&R Works, MITSUBISHI ELECTRIC CORPORATION	
	Starting method		Inverter		
	Motor output	kW	4.6	6.3	
	Case heater	kW	0.035(240 V)	0.035(240 V)	
	Lubricant		MEL32		
External finish			Acrylic painted steel plate		
External dimension HxWxD	mm		1,160(1,100 without legs) x 880 x 550	1,160(1,100 without legs) x 880 x 550	
	in.		45-11/16(43-5/16 without legs) x 34-11/16 x 21-11/16	45-11/16(43-5/16 without legs) x 34-11/16 x 21-11/16	
Protection devices	High pressure protection		High pressure sensor, High pressure switch at 4.15MPa (601 psi)		
	Inverter circuit (COMP.)		Over-heat protection, Over-current protection		
	Compressor		Over-heat protection		
Refrigerant	Type x original charge		R410A x 5.0kg (12lbs)		
	Control		Indoor LEV and BC controller		
Net weight	kg (lbs)		181(400)	181(400)	
Heat exchanger			plate type		
	Water volume in plate	l	5.0	5.0	
	Water pressure Max.	MPa	2.0	2.0	
HIC circuit (HIC: Heat Inter-Changer)			-		
Drawing	External		KB94T146		
	Wiring		KE94C302		
Standard attachment	Document		Installation Manual		
	Accessory		Refrigerant conn. pipe		
Optional parts	Joint: CMY-Y102SS-G2, CMY-Y102LS-G2, CMY-Y202S-G2, CMY-R160-J1		Joint: CMY-Y102SS-G2, CMY-Y102LS-G2, CMY-Y202S-G2, CMY-R160-J1		
	BC controller: CMB-P104, 105, 106, 108, 1010, 1013, 1016V-G1 Main BC controller: CMB-P108, 1010, 1013, 1016V-GA1 Sub BC controller: CMB-P104, 108V-GB1, CMB-P1016V-HB1		BC controller: CMB-P104, 105, 106, 108, 1010, 1013, 1016V-G1 Main BC controller: CMB-P108, 1010, 1013, 1016V-GA1 Sub BC controller: CMB-P104, 108V-GB1, CMB-P1016V-HB1		
Remarks			<ul style="list-style-type: none"> •Details on foundation work, duct work, insulation work, electrical wiring, power source switch, and other items shall be referred to the Installation Manual. •Due to continuing improvement, above specifications may be subject to change without notice. •The ambient temperature of the heat source unit needs to be kept below 40°C D.B. •The ambient relative humidity of the heat source unit needs to be kept below 80%. •The heat source Unit should not be installed at outdoor. •Be sure to mount a strainer (more than 50 meshes) at the water inlet piping of the unit. •Be sure to provide interlocking for the unit operation and water circuit. 		

WR2

Notes:	Unit converter
1. Nominal cooling conditions (subject to JIS B8615-2) Indoor: 27°CDB/19°CWB (81°FDB/66°FWB), Water temperature: 30°C (86°F) Pipe length: 7.5m (24-9/16ft.), Level difference: 0m (0ft.)	kcal/h =kW x 860 BTU/h =kW x 3,412 cfm =m ³ /min x 35.31 lbs =kg/0.4536
2. Nominal heating conditions (subject to JIS B8615-2) Indoor: 20°CDB (68°FDB), Water temperature: 20°C (68°F) Pipe length: 7.5m (24-9/16ft.), Level difference: 0m (0ft.)	*The specification data is subject to rounding variation.

1. SPECIFICATIONS

G10 2nd

Model		PQRY-P300YHM-A	
Power source		3-phase 4-wire 380-400-415V 50/60Hz	
Cooling capacity (Nominal)	*1 kW	33.5	
	*1 kcal / h	28,800	
	*1 BTU / h	114,300	
	Power input	kW	7.44
	Current input	A	12.5-11.9-11.5
Temp. range of cooling	EER	kW / kW	4.50
	Indoor	W.B.	15.0 ~ 24.0°C(59 ~ 75°F)
	Circulating water	°C	10.0 ~ 45.0°C(50 ~ 113°F)
Heating capacity (Nominal)	*2 kW	37.5	
	*2 kcal / h	32,300	
	*2 BTU / h	128,000	
	Power input	kW	8.15
	Current input	A	13.7-13.0-12.5
Temp. range of heating	COP	kW / kW	4.60
	Indoor	D.B.	15.0 ~ 27.0°C(59 ~ 81°F)
Indoor unit connectable	Circulating water	°C	10.0 ~ 45.0°C(50 ~ 113°F)
	Total capacity	50 ~ 150 % of heat source unit capacity	
Sound pressure level (measured in anechoic room)	Model / Quantity	P15 ~ P250 / 1 ~ 30	
Refrigerant piping diameter	dB <A>	50	
	High pressure	mm (in.)	19.05(3/4) Brazed
Circulating water	Low pressure	mm (in.)	22.2(7/8) Brazed
	Water flow rate	m ³ / h	5.76
		L / min	96
		cfm	3.4
Pressure drop	kPa	17	
Operating volume range	m ³ / h	4.5 ~ 7.2	
Compressor	Type x Quantity	Inverter scroll hermetic compressor	
	Manufacture	AC&R Works, MITSUBISHI ELECTRIC CORPORATION	
	Starting method	Inverter	
	Motor output	kW	7.4
	Case heater	kW	0.035(240 V)
	Lubricant	MEL32	
External finish	Acrylic painted steel plate		
External dimension HxWxD	mm	1,160(1,100 without legs) x 880 x 550	
	in.	45-11/16(43-5/16 without legs) x 34-11/16 x 21-11/16	
Protection devices	High pressure protection	High pressure sensor, High pressure switch at 4.15MPa (601 psi)	
	Inverter circuit (COMP.)	Over-heat protection, Over-current protection	
	Compressor	Over-heat protection	
Refrigerant	Type x original charge	R410A x 5.0kg (12lbs)	
	Control	Indoor LEV and BC controller	
Net weight	kg (lbs)	181(400)	
Heat exchanger	plate type		
	Water volume in plate	l	5.0
	Water pressure Max.	MPa	2.0
HIC circuit (HIC: Heat Inter-Changer)	-		
Drawing	External	KB94T146	
	Wiring	KE94C302	
Standard attachment	Document	Installation Manual	
	Accessory	Refrigerant conn. pipe	
Optional parts	Joint: CMY-Y102SS-G2, CMY-Y102LS-G2, CMY-Y202S-G2, CMY-R160-J1 BC controller: CMB-P104, 105, 106, 108, 1010, 1013, 1016V-G1 Main BC controller: CMB-P108, 1010, 1013, 1016V-GA1 Sub BC controller: CMB-P104, 108V-GB1, CMB-P1016V-HB1		
Remarks	<ul style="list-style-type: none"> •Details on foundation work, duct work, insulation work, electrical wiring, power source switch, and other items shall be referred to the Installation Manual. •Due to continuing improvement, above specifications may be subject to change without notice. •The ambient temperature of the heat source unit needs to be kept below 40°C D.B. •The ambient relative humidity of the heat source unit needs to be kept below 80%. •The heat source Unit should not be installed at outdoor. •Be sure to mount a strainer (more than 50 meshes) at the water inlet piping of the unit. •Be sure to provide interlocking for the unit operation and water circuit. 		

WR2

Notes:	Unit converter
1. Nominal cooling conditions (subject to JIS B8615-2) Indoor: 27°CDB/19°CWB (81°FDB/66°FWB), Water temperature: 30°C (86°F) Pipe length: 7.5m (24-9/16ft.), Level difference: 0m (0ft.)	kcal/h =kW x 860 BTU/h =kW x 3,412 cfm =m ³ /min x 35.31 lbs =kg/0.4536
2. Nominal heating conditions (subject to JIS B8615-2) Indoor: 20°CDB (68°FDB), Water temperature: 20°C (68°F) Pipe length: 7.5m (24-9/16ft.), Level difference: 0m (0ft.)	*The specification data is subject to rounding variation.

1. SPECIFICATIONS

G10 2nd

Model			PQRY-P400YSHM-A			
Power source			3-phase 4-wire 380-400-415V 50/60Hz			
Cooling capacity (Nominal)	*1	kW	45.0			
	*1	kcal / h	38,700			
	*1	BTU / h	153,500			
	Power input		kW	8.32		
	Current input		A	14.0-13.3-12.8		
EER		kW / kW	5.40			
Temp. range of cooling	Indoor	W.B.	15.0 ~ 24.0°C(59 ~ 75°F)			
	Circulating water	°C	10.0 ~ 45.0°C(50 ~ 113°F)			
Heating capacity (Nominal)	*2	kW	50.0			
	*2	kcal / h	43,000			
	*2	BTU / h	170,600			
	Power input		kW	8.65		
	Current input		A	14.6-13.8-13.3		
COP		kW / kW	5.78			
Temp. range of heating	Indoor	D.B.	15.0 ~ 27.0°C(59 ~ 81°F)			
	Circulating water	°C	10.0 ~ 45.0°C(50 ~ 113°F)			
Indoor unit connectable	Total capacity		50 ~ 150 % of heat source unit capacity			
	Model / Quantity		P15 ~ P250 / 1 ~ 40			
Sound pressure level (measured in anechoic room)		dB <A>	50			
Refrigerant piping diameter	High pressure	mm (in.)	22.2(7/8) Brazed			
	Low pressure	mm (in.)	28.58(1-1/8) Brazed			
Set Model						

Model			PQRY-P200YHM-A		PQRY-P200YHM-A	
Circulating water	Water flow rate	m ³ / h	5.76 + 5.76			
		L / min	96 + 96			
		cfm	3.4 + 3.4			
	Pressure drop	kPa	17		17	
Operating volume range		m ³ / h	4.5 + 4.5 ~ 7.2 + 7.2			
Compressor	Type x Quantity		Inverter scroll hermetic compressor		Inverter scroll hermetic compressor	
	Manufacture		AC&R Works, MITSUBISHI ELECTRIC CORPORATION		AC&R Works, MITSUBISHI ELECTRIC CORPORATION	
	Starting method		Inverter		Inverter	
	Motor output	kW	4.6		4.6	
	Case heater	kW	0.035(240 V)		0.035(240 V)	
	Lubricant		MEL32		MEL32	
External finish			Acrylic painted steel plate		Acrylic painted steel plate	
External dimension HxWxD		mm	1,160(1,100 without legs) x 880 x 550		1,160(1,100 without legs) x 880 x 550	
		in.	45-11/16(43-5/16 without legs) x 34-11/16 x 21-11/16		45-11/16(43-5/16 without legs) x 34-11/16 x 21-11/16	
Protection devices	High pressure protection		High pressure sensor, High pressure switch at 4.15MPa (601 psi)		High pressure sensor, High pressure switch at 4.15MPa (601 psi)	
	Inverter circuit (COMP.)		Over-heat protection, Over-current protection		Over-heat protection, Over-current protection	
	Compressor		Over-heat protection		Over-heat protection	
Refrigerant	Type x original charge		R410A x 5.0kg (12lbs)		R410A x 5.0kg (12lbs)	
	Control		Indoor LEV and BC controller			
Net weight		kg (lbs)	181(400)		181(400)	
Heat exchanger			plate type		plate type	
	Water volume in plate	l	5.0		5.0	
	Water pressure Max.	MPa	2.0		2.0	
HIC circuit (HIC: Heat Inter-Changer)			-		-	
Pipe between unit and distributor	High pressure	mm (in.)	19.05(3/4) Brazed		19.05(3/4) Brazed	
	Low pressure	mm (in.)	-		22.2(7/8) Brazed	
Drawing	External		KB94T147			
	Wiring		KE94C302		KE94C302	
Standard attachment	Document		Installation Manual			
	Accessory		Refrigerant conn. pipe			
Optional parts			Heat Source Twinning kit: CMY-Q100VBK Joint: CMY-Y102SS-G2, CMY-Y102LS-G2, CMY-Y202S-G2, CMY-R160-J1 Main BC controller: CMB-P108, 1010, 1013, 1016V-GA1 Sub BC controller: CMB-P104, 108V-GB1, CMB-P1016V-HB1			
Remarks			<ul style="list-style-type: none"> •Details on foundation work, duct work, insulation work, electrical wiring, power source switch, and other items shall be referred to the Installation Manual. •Due to continuing improvement, above specifications may be subject to change without notice. •The ambient temperature of the heat source unit needs to be kept below 40°C D.B. •The ambient relative humidity of the heat source unit needs to be kept below 80%. •The heat source Unit should not be installed at outdoor. •Be sure to mount a strainer (more than 50 meshes) at the water inlet piping of the unit. •Be sure to provide interlocking for the unit operation and water circuit. •The heat source twinning kit (low pressure) should be connected to the low pressure side of the heat source unit. If the connected units are of different capacities, the heat source twinning kit (low pressure) should be installed in the unit with the largest capacity.			

Notes:	Unit converter
1. Nominal cooling conditions (subject to JIS B8615-2) Indoor: 27°CDB/19°CWB (81°FDB/66°FWB), Water temperature: 30°C (86°F) Pipe length: 7.5m (24-9/16ft.), Level difference: 0m (0ft.)	kcal/h =kW x 860 BTU/h =kW x 3,412 cfm =m ³ /min x 35.31 lbs =kg/0.4536
2. Nominal heating conditions (subject to JIS B8615-2) Indoor: 20°CDB (68°FDB), Water temperature: 20°C (68°F) Pipe length: 7.5m (24-9/16ft.), Level difference: 0m (0ft.)	*The specification data is subject to rounding variation.

1. SPECIFICATIONS

G10 2nd

Model		PQRY-P450YSHM-A	
Power source		3-phase 4-wire 380-400-415V 50/60Hz	
Cooling capacity (Nominal)	*1 kW	50.0	
	*1 kcal / h	43,000	
	*1 BTU / h	170,600	
	Power input	kW	9.94
	Current input	A	16.7-15.9-15.3
Temp. range of cooling	EER	kW / kW	5.03
	Indoor	W.B.	15.0 ~ 24.0°C(59 ~ 75°F)
	Circulating water	°C	10.0 ~ 45.0°C(50 ~ 113°F)
Heating capacity (Nominal)	*2 kW	56.0	
	*2 kcal / h	48,200	
	*2 BTU / h	191,100	
	Power input	kW	10.42
	Current input	A	17.5-16.7-16.1
Temp. range of heating	COP	kW / kW	5.37
	Indoor	D.B.	15.0 ~ 27.0°C(59 ~ 81°F)
	Circulating water	°C	10.0 ~ 45.0°C(50 ~ 113°F)
Indoor unit connectable	Total capacity	50 ~ 150 % of heat source unit capacity	
	Model / Quantity	P15 ~ P250 / 1 ~ 45	
Sound pressure level (measured in anechoic room)	dB <A>	51	
Refrigerant piping diameter	High pressure	mm (in.)	22.2(7/8) Brazed
	Low pressure	mm (in.)	28.58(1-1/8) Brazed

Set Model

Model		PQRY-P250YHM-A		PQRY-P200YHM-A		
Circulating water	Water flow rate	m ³ / h	5.76 + 5.76			
		L / min	96 + 96			
		cfm	3.4 + 3.4			
	Pressure drop	kPa	17	17		
Operating volume range	m ³ / h	4.5 + 4.5 ~ 7.2 + 7.2				
Compressor	Type x Quantity		Inverter scroll hermetic compressor		Inverter scroll hermetic compressor	
	Manufacture		AC&R Works, MITSUBISHI ELECTRIC CORPORATION		AC&R Works, MITSUBISHI ELECTRIC CORPORATION	
	Starting method		Inverter		Inverter	
	Motor output	kW	6.3		4.6	
	Case heater	kW	0.035(240 V)		0.035(240 V)	
	Lubricant		MEL32		MEL32	
External finish		Acrylic painted steel plate		Acrylic painted steel plate		
External dimension HxWxD		mm	1,160(1,100 without legs) x 880 x 550		1,160(1,100 without legs) x 880 x 550	
		in.	45-11/16(43-5/16 without legs) x 34-11/16 x 21-11/16		45-11/16(43-5/16 without legs) x 34-11/16 x 21-11/16	
Protection devices	High pressure protection		High pressure sensor, High pressure switch at 4.15MPa (601 psi)		High pressure sensor, High pressure switch at 4.15MPa (601 psi)	
	Inverter circuit (COMP.)		Over-heat protection, Over-current protection		Over-heat protection, Over-current protection	
	Compressor		Over-heat protection		Over-heat protection	
Refrigerant	Type x original charge		R410A x 5.0kg (12lbs)		R410A x 5.0kg (12lbs)	
	Control		Indoor LEV and BC controller			
Net weight		kg (lbs)	181(400)		181(400)	
Heat exchanger			plate type		plate type	
	Water volume in plate	l	5.0		5.0	
	Water pressure Max.	MPa	2.0		2.0	
HIC circuit (HIC: Heat Inter-Changer)		-				
Pipe between unit and distributor	High pressure	mm (in.)	19.05(3/4) Brazed		19.05(3/4) Brazed	
	Low pressure	mm (in.)	-		22.2(7/8) Brazed	
Drawing	External		KB94T147			
	Wiring		KE94C302		KE94C302	
Standard attachment	Document		Installation Manual			
	Accessory		Refrigerant conn. pipe			
Optional parts		Heat Source Twinning kit: CMY-Q100VBK Joint: CMY-Y102SS-G2, CMY-Y102LS-G2, CMY-Y202S-G2, CMY-R160-J1 Main BC controller: CMB-P108, 1010, 1013, 1016V-GA1 Sub BC controller: CMB-P104, 108V-GB1, CMB-P1016V-HB1				
Remarks		<ul style="list-style-type: none"> •Details on foundation work, duct work, insulation work, electrical wiring, power source switch, and other items shall be referred to the Installation Manual. •Due to continuing improvement, above specifications may be subject to change without notice. •The ambient temperature of the heat source unit needs to be kept below 40°C D.B. •The ambient relative humidity of the heat source unit needs to be kept below 80%. •The heat source Unit should not be installed at outdoor. •Be sure to mount a strainer (more than 50 meshes) at the water inlet piping of the unit. •Be sure to provide interlocking for the unit operation and water circuit. •The heat source twinning kit (low pressure) should be connected to the low pressure side of the heat source unit. If the connected units are of different capacities, the heat source twinning kit (low pressure) should be installed in the unit with the largest capacity.				

Notes:	Unit converter
1. Nominal cooling conditions (subject to JIS B8615-2) Indoor: 27°CDB/19°CWB (81°FDB/66°FWB), Water temperature: 30°C (86°F) Pipe length: 7.5m (24-9/16ft.), Level difference: 0m (0ft.)	kcal/h =kW x 860 BTU/h =kW x 3,412 cfm =m ³ /min x 35.31 lbs =kg/0.4536
2. Nominal heating conditions (subject to JIS B8615-2) Indoor: 20°CDB (68°FDB), Water temperature: 20°C (68°F) Pipe length: 7.5m (24-9/16ft.), Level difference: 0m (0ft.)	*The specification data is subject to rounding variation.

1. SPECIFICATIONS

G10 2nd

Model			PQRY-P500YSHM-A			
Power source			3-phase 4-wire 380-400-415V 50/60Hz			
Cooling capacity (Nominal)	*1	kW	56.0			
	*1	kcal / h	48,200			
	*1	BTU / h	191,100			
	Power input		kW	11.57		
	Current input		A	19.5-18.5-17.8		
EER		kW / kW	4.84			
Temp. range of cooling	Indoor	W.B.	15.0 ~ 24.0°C(59 ~ 75°F)			
	Circulating water	°C	10.0 ~ 45.0°C(50 ~ 113°F)			
Heating capacity (Nominal)	*2	kW	63.0			
	*2	kcal / h	54,200			
	*2	BTU / h	215,000			
	Power input		kW	12.06		
	Current input		A	20.3-19.3-18.6		
COP		kW / kW	5.22			
Temp. range of heating	Indoor	D.B.	15.0 ~ 27.0°C(59 ~ 81°F)			
	Circulating water	°C	10.0 ~ 45.0°C(50 ~ 113°F)			
Indoor unit connectable	Total capacity		50 ~ 150 % of heat source unit capacity			
Model / Quantity		P15 ~ P250 / 1 ~ 50 (Connectable branch pipe number is max. 48.)				
Sound pressure level (measured in anechoic room)		dB <A>	52			
Refrigerant piping diameter	High pressure	mm (in.)	22.2(7/8) Brazed			
Low pressure		mm (in.)	28.58(1-1/8) Brazed			

Set Model						
Model			PQRY-P250YHM-A		PQRY-P250YHM-A	
Circulating water	Water flow rate	m ³ / h	5.76 + 5.76			
		L / min	96 + 96			
		cfm	3.4 + 3.4			
	Pressure drop	kPa	17		17	
Operating volume range		m ³ / h	4.5 + 4.5 ~ 7.2 + 7.2			
Compressor	Type x Quantity		Inverter scroll hermetic compressor		Inverter scroll hermetic compressor	
	Manufacture		AC&R Works, MITSUBISHI ELECTRIC CORPORATION		AC&R Works, MITSUBISHI ELECTRIC CORPORATION	
	Starting method		Inverter		Inverter	
	Motor output	kW	6.3		6.3	
	Case heater	kW	0.035(240 V)		0.035(240 V)	
	Lubricant		MEL32		MEL32	
External finish			Acrylic painted steel plate		Acrylic painted steel plate	
External dimension HxWxD		mm	1,160(1,100 without legs) x 880 x 550		1,160(1,100 without legs) x 880 x 550	
		in.	45-11/16(43-5/16 without legs) x 34-11/16 x 21-11/16		45-11/16(43-5/16 without legs) x 34-11/16 x 21-11/16	
Protection devices	High pressure protection		High pressure sensor, High pressure switch at 4.15MPa (601 psi)		High pressure sensor, High pressure switch at 4.15MPa (601 psi)	
	Inverter circuit (COMP.)		Over-heat protection, Over-current protection		Over-heat protection, Over-current protection	
	Compressor		Over-heat protection		Over-heat protection	
Refrigerant	Type x original charge		R410A x 5.0kg (12lbs)		R410A x 5.0kg (12lbs)	
	Control		Indoor LEV and BC controller			
Net weight		kg (lbs)	181(400)		181(400)	
Heat exchanger			plate type		plate type	
	Water volume in plate	l	5.0		5.0	
	Water pressure Max.	MPa	2.0		2.0	
HIC circuit (HIC: Heat Inter-Changer)			-		-	
Pipe between unit and distributor	High pressure	mm (in.)	19.05(3/4) Brazed		19.05(3/4) Brazed	
	Low pressure	mm (in.)	-		22.2(7/8) Brazed	
Drawing	External		KB94T147			
	Wiring		KE94C302		KE94C302	
Standard attachment	Document		Installation Manual			
	Accessory		Refrigerant conn. pipe			
Optional parts			Heat Source Twinning kit: CMY-Q100VBK Joint: CMY-Y102SS-G2, CMY-Y102LS-G2, CMY-Y202S-G2, CMY-R160-J1 Main BC controller: CMB-P108, 1010, 1013, 1016V-GA1 Sub BC controller: CMB-P104, 108V-GB1, CMB-P1016V-HB1			
Remarks			<ul style="list-style-type: none"> •Details on foundation work, duct work, insulation work, electrical wiring, power source switch, and other items shall be referred to the Installation Manual. •Due to continuing improvement, above specifications may be subject to change without notice. •The ambient temperature of the heat source unit needs to be kept below 40°C D.B. •The ambient relative humidity of the heat source unit needs to be kept below 80%. •The heat source Unit should not be installed at outdoor. •Be sure to mount a strainer (more than 50 meshes) at the water inlet piping of the unit. •Be sure to provide interlocking for the unit operation and water circuit. •The heat source twinning kit (low pressure) should be connected to the low pressure side of the heat source unit. <p>If the connected units are of different capacities, the heat source twinning kit (low pressure) should be installed in the unit with the largest capacity.</p>			

Notes:		Unit converter	
1. Nominal cooling conditions (subject to JIS B8615-2) Indoor: 27°CDB/19°CWB (81°FDB/66°FWB), Water temperature: 30°C (86°F) Pipe length: 7.5m (24-9/16ft.), Level difference: 0m (0ft.)		kcal/h	=kW x 860
2. Nominal heating conditions (subject to JIS B8615-2) Indoor: 20°CDB (68°FDB), Water temperature: 20°C (68°F) Pipe length: 7.5m (24-9/16ft.), Level difference: 0m (0ft.)		BTU/h	=kW x 3,412
		cfm	=m ³ /min x 35.31
		lbs	=kg/0.4536
		*The specification data is subject to rounding variation.	

1. SPECIFICATIONS

Model			PQRY-P550YSHM-A	
Power source	3-phase 4-wire 380-400-415V 50/60Hz			
Cooling capacity (Nominal)	*1	kW	63.0	
	*1	kcal / h	54,200	
	*1	BTU / h	215,000	
	Power input	kW	13.60	
	Current input	A	22.9-21.8-21.0	
Temp. range of cooling	EER	kW / kW	4.63	
	Indoor	W.B.	15.0 ~ 24.0°C(59 ~ 75°F)	
	Circulating water	°C	10.0 ~ 45.0°C(50 ~ 113°F)	
Heating capacity (Nominal)	*2	kW	69.0	
	*2	kcal / h	59,300	
	*2	BTU / h	235,400	
	Power input	kW	14.65	
	Current input	A	24.7-23.4-22.6	
Temp. range of heating	COP	kW / kW	4.70	
	Indoor	D.B.	15.0 ~ 27.0°C(59 ~ 81°F)	
	Circulating water	°C	10.0 ~ 45.0°C(50 ~ 113°F)	
Indoor unit connectable	Total capacity	50 ~ 150 % of heat source unit capacity		
	Model / Quantity	P15 ~ P250 / 2 ~ 50 (Connectable branch pipe number is max. 48.)		
Sound pressure level (measured in anechoic room)	dB <A>	52.5		
Refrigerant piping diameter	High pressure	mm (in.)	28.58(1-1/8) Brazed	
	Low pressure	mm (in.)	28.58(1-1/8) Brazed	

Model			PQRY-P300YHM-A		PQRY-P250YHM-A	
Circulating water	Water flow rate	m ³ / h	5.76 + 5.76			
		L / min	96 + 96			
		cfm	3.4 + 3.4			
	Pressure drop	kPa	17		17	
Operating volume range	m ³ / h	4.5 + 4.5 ~ 7.2 + 7.2				
Compressor	Type x Quantity		Inverter scroll hermetic compressor		Inverter scroll hermetic compressor	
	Manufacture		AC&R Works, MITSUBISHI ELECTRIC CORPORATION		AC&R Works, MITSUBISHI ELECTRIC CORPORATION	
	Starting method		Inverter		Inverter	
	Motor output	kW	7.4		6.3	
	Case heater	kW	0.035(240 V)		0.035(240 V)	
	Lubricant		MEL32		MEL32	
External finish			Acrylic painted steel plate		Acrylic painted steel plate	
External dimension HxWxD		mm	1,160(1,100 without legs) x 880 x 550		1,160(1,100 without legs) x 880 x 550	
		in.	45-11/16(43-5/16 without legs) x 34-11/16 x 21-11/16		45-11/16(43-5/16 without legs) x 34-11/16 x 21-11/16	
Protection devices	High pressure protection		High pressure sensor, High pressure switch at 4.15MPa (601 psi)		High pressure sensor, High pressure switch at 4.15MPa (601 psi)	
	Inverter circuit (COMP.)		Over-heat protection, Over-current protection		Over-heat protection, Over-current protection	
	Compressor		Over-heat protection		Over-heat protection	
Refrigerant	Type x original charge		R410A x 5.0kg (12lbs)		R410A x 5.0kg (12lbs)	
	Control		Indoor LEV and BC controller			
Net weight		kg (lbs)	181(400)		181(400)	
Heat exchanger			plate type		plate type	
	Water volume in plate	l	5.0		5.0	
	Water pressure Max.	MPa	2.0		2.0	
HIC circuit (HIC: Heat Inter-Changer)			-		-	
Pipe between unit and distributor	High pressure	mm (in.)	19.05(3/4) Brazed		19.05(3/4) Brazed	
	Low pressure	mm (in.)	-		22.2(7/8) Brazed	
Drawing	External		KB94T147			
	Wiring		KE94C302		KE94C302	
Standard attachment	Document		Installation Manual			
	Accessory		Refrigerant conn. pipe			
Optional parts			Heat Source Twinning kit: CMY-Q100VBK Joint: CMY-Y102SS-G2, CMY-Y102LS-G2, CMY-Y202S-G2, CMY-R160-J1 Main BC controller: CMB-P108, 1010, 1013, 1016V-GA1 Sub BC controller: CMB-P104, 108V-GB1, CMB-P1016V-HB1			
Remarks			<ul style="list-style-type: none"> •Details on foundation work, duct work, insulation work, electrical wiring, power source switch, and other items shall be referred to the Installation Manual. •Due to continuing improvement, above specifications may be subject to change without notice •The ambient temperature of the heat source unit needs to be kept below 40°C D.B. •The ambient relative humidity of the heat source unit needs to be kept below 80%. •The heat source Unit should not be installed at outdoor. •Be sure to mount a strainer (more than 50 meshes) at the water inlet piping of the unit. •Be sure to provide interlocking for the unit operation and water circuit. •The heat source twinning kit (low pressure) should be connected to the low pressure side of the heat source unit. If the connected units are of different capacities, the heat source twinning kit (low pressure) should be installed in the unit with the largest capacity.			

Notes:	Unit converter
1. Nominal cooling conditions (subject to JIS B8615-2) Indoor: 27°CDB/19°CWB (81°FDB/66°FWB), Water temperature: 30°C (86°F) Pipe length: 7.5m (24-9/16ft.), Level difference: 0m (0ft.)	kcal/h =kW x 860 BTU/h =kW x 3,412 cfm =m ³ /min x 35.31 lbs =kg/0.4536
2. Nominal heating conditions (subject to JIS B8615-2) Indoor: 20°CDB (68°FDB), Water temperature: 20°C (68°F) Pipe length: 7.5m (24-9/16ft.), Level difference: 0m (0ft.)	*The specification data is subject to rounding variation.

1. SPECIFICATIONS

G10 2nd

Model			PQRY-P600YSHM-A			
Power source			3-phase 4-wire 380-400-415V 50/60Hz			
Cooling capacity (Nominal)	*1	kW	69.0			
	*1	kcal / h	59,300			
	*1	BTU / h	235,400			
	Power input		kW	15.62		
	Current input		A	26.3-25.0-24.1		
EER		kW / kW	4.41			
Temp. range of cooling	Indoor	W.B.	15.0 ~ 24.0°C(59 ~ 75°F)			
	Circulating water	°C	10.0 ~ 45.0°C(50 ~ 113°F)			
Heating capacity (Nominal)	*2	kW	76.5			
	*2	kcal / h	65,800			
	*2	BTU / h	261,000			
	Power input		kW	17.12		
	Current input		A	28.9-27.4-26.4		
COP		kW / kW	4.46			
Temp. range of heating	Indoor	D.B.	15.0 ~ 27.0°C(59 ~ 81°F)			
	Circulating water	°C	10.0 ~ 45.0°C(50 ~ 113°F)			
Indoor unit connectable	Total capacity		50 ~ 150 % of heat source unit capacity			
Model / Quantity		P15 ~ P250 / 2 ~ 50 (Connectable branch pipe number is max. 48.)				
Sound pressure level (measured in anechoic room)		dB <A>	53			
Refrigerant piping diameter	High pressure	mm (in.)	28.58(1-1/8) Brazed			
	Low pressure	mm (in.)	28.58(1-1/8) Brazed			
Set Model						

Model			PQRY-P300YHM-A		PQRY-P300YHM-A	
Circulating water	Water flow rate	m ³ / h	5.76 + 5.76			
		L / min	96 + 96			
		cfm	3.4 + 3.4			
	Pressure drop	kPa	17		17	
Operating volume range		m ³ / h	4.5 + 4.5 ~ 7.2 + 7.2			
Compressor	Type x Quantity		Inverter scroll hermetic compressor		Inverter scroll hermetic compressor	
	Manufacture		AC&R Works, MITSUBISHI ELECTRIC CORPORATION		AC&R Works, MITSUBISHI ELECTRIC CORPORATION	
	Starting method		Inverter		Inverter	
	Motor output	kW	7.4		7.4	
	Case heater	kW	0.035(240 V)		0.035(240 V)	
	Lubricant		MEL32		MEL32	
External finish			Acrylic painted steel plate		Acrylic painted steel plate	
External dimension HxWxD		mm	1,160(1,100 without legs) x 880 x 550		1,160(1,100 without legs) x 880 x 550	
		in.	45-11/16(43-5/16 without legs) x 34-11/16 x 21-11/16		45-11/16(43-5/16 without legs) x 34-11/16 x 21-11/16	
Protection devices	High pressure protection		High pressure sensor, High pressure switch at 4.15MPa (601 psi)		High pressure sensor, High pressure switch at 4.15MPa (601 psi)	
	Inverter circuit (COMP.)		Over-heat protection, Over-current protection		Over-heat protection, Over-current protection	
	Compressor		Over-heat protection		Over-heat protection	
Refrigerant	Type x original charge		R410A x 5.0kg (12lbs)		R410A x 5.0kg (12lbs)	
	Control		Indoor LEV and BC controller			
Net weight		kg (lbs)	181(400)		181(400)	
Heat exchanger			plate type		plate type	
	Water volume in plate	l	5.0		5.0	
	Water pressure Max.	MPa	2.0		2.0	
HIC circuit (HIC: Heat Inter-Changer)			-		-	
Pipe between unit and distributor	High pressure	mm (in.)	19.05(3/4) Brazed		19.05(3/4) Brazed	
	Low pressure	mm (in.)	-		22.2(7/8) Brazed	
Drawing	External		KB94T147			
	Wiring		KE94C302		KE94C302	
Standard attachment	Document		Installation Manual			
	Accessory		Refrigerant conn. pipe			
Optional parts			Heat Source Twinning kit: CMY-Q100VBK Joint: CMY-Y102SS-G2, CMY-Y102LS-G2, CMY-Y202S-G2, CMY-R160-J1 Main BC controller: CMB-P108, 1010, 1013, 1016V-GA1 Sub BC controller: CMB-P104, 108V-GB1, CMB-P1016V-HB1			
Remarks			<ul style="list-style-type: none"> •Details on foundation work, duct work, insulation work, electrical wiring, power source switch, and other items shall be referred to the Installation Manual. •Due to continuing improvement, above specifications may be subject to change without notice. •The ambient temperature of the heat source unit needs to be kept below 40°C D.B. •The ambient relative humidity of the heat source unit needs to be kept below 80%. •The heat source Unit should not be installed at outdoor. •Be sure to mount a strainer (more than 50 meshes) at the water inlet piping of the unit. •Be sure to provide interlocking for the unit operation and water circuit. •The heat source twinning kit (low pressure) should be connected to the low pressure side of the heat source unit. If the connected units are of different capacities, the heat source twinning kit (low pressure) should be installed in the unit with the largest capacity.			

Notes:	Unit converter
1. Nominal cooling conditions (subject to JIS B8615-2) Indoor: 27°CDB/19°CWB (81°FDB/66°FWB), Water temperature: 30°C (86°F) Pipe length: 7.5m (24-9/16ft.), Level difference: 0m (0ft.)	kcal/h =kW x 860 BTU/h =kW x 3,412 cfm =m ³ /min x 35.31 lbs =kg/0.4536
2. Nominal heating conditions (subject to JIS B8615-2) Indoor: 20°CDB (68°FDB), Water temperature: 20°C (68°F) Pipe length: 7.5m (24-9/16ft.), Level difference: 0m (0ft.)	*The specification data is subject to rounding variation.

PQRY-P200, 250, 300YHM-A

Unit : mm

- Note 1. Close a hole of the water piping, the refrigerant piping, the power supply, and the control wiring and unused knockout holes with the putty etc. so as not to infiltrate rain water etc. (field erection work)
- Note 2. At the time of product shipment, the front side piping specification serves as the local drainage connection. When connecting on the rear side, please remove the rear side plug sealing corks, and attach a front side. Ensure there is no leak after the attachment has been fitted.
- Note 3. Take notice of service space as Fig. A. (In case of single installation, 600mm or more of back space as front space makes easier access when servicing the unit from rear side)
- Note 4. If water pipes or refrigerant pipes stretch upward, required space for service and maintenance due to replacement of control box is shown in Fig. B.
- Note 5. Environmental condition for installation; -20~40°C (DB) as indoor installation.
- Note 6. In case the temperature around the heat source unit has possibility to drop under 0°C, be careful for the following point to prevent the pipe burst by the water pipe freeze-up.
 - Circulate the water all the time even if the heat source unit is not in operation.
 - Drain the water from inside of the heat source unit when the heat source unit will not operate for a long term.
- Note 7. Ensure that the drain piping is downward with a pitch of more than 1/100.
- Note 8. The detachable leg can be removed at site.
- Note 9. At brazing of pipes, wrap the refrigerant service valve with wet cloth and keep the temperature of refrigerant service valve under 120°C.

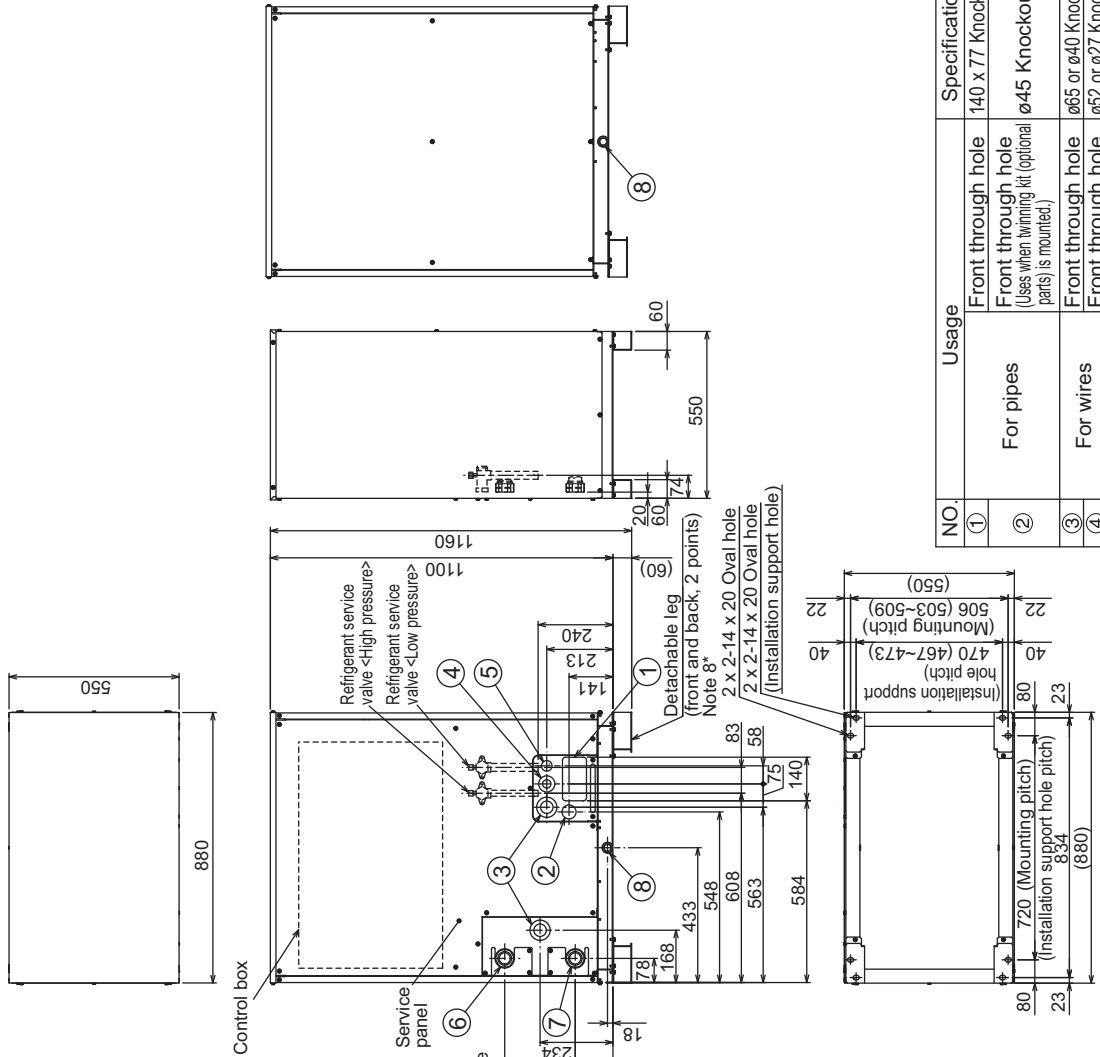

Fig. A

Fig. B

<Accessories>
 -Refrigerant (high pressure) conn. pipe1 pc. (P200 ; Packaged in the accessory kit)
 -Refrigerant (low pressure) conn. pipe1 pc. (P200/P250 ; Packaged in the accessory kit)

Connecting pipe specifications

Model	Connection specifications for the refrigerant service valve	
	High pressure	Low pressure
PQRY-P200YHM-A	ø15.88 Brazed*2	ø19.05 Brazed*2
PQRY-P250YHM-A	ø19.05 Brazed*1	ø22.2 Brazed*2
PQRY-P300YHM-A		

*1. Expand the field pipes and connect directly to the valve.
 *2. Connect by using the connecting pipes that are supplied.

NO.	Usage	Specifications
①	Front through hole	140 x 77 Knockout hole
②	For pipes	Front through hole (Uses when wiring kit (optional parts) is mounted.) ø45 Knockout hole
③	For wires	Front through hole ø65 or ø40 Knockout hole
④	For transmission cables	Front through hole ø52 or ø27 Knockout hole
⑤	Water pipe inlet	Front through hole ø34 Knockout hole
⑥	Water pipe outlet	Rc1-1/2 Screw
⑦	Drain pipe	Rc3/4 Screw

WR2

2. EXTERNAL DIMENSIONS

G10 2nd

PQRY-P400,450,500,550,600YSHM-A

Unit : mm

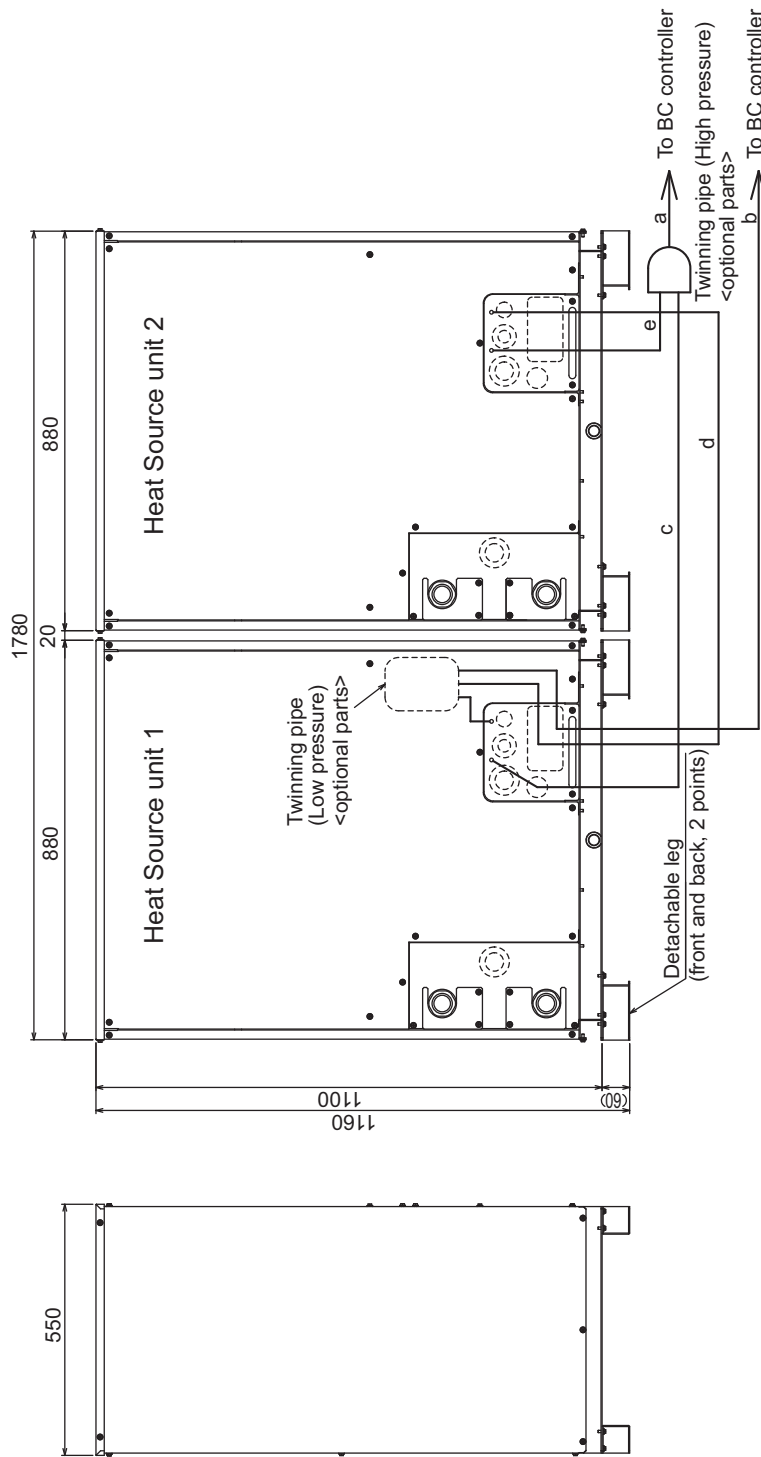

- Note 1. Connect the pipes as shown in the figure above. Refer to the table below for the pipe size.
 2. The detachable leg can be removed at site.
 3. Twinning pipe (High pressure) should not be tilted more than 15 degrees from the ground.
 4. See the Installation Manual for the details of Twinning pipe installation.

Twinning pipe connection size

Package unit name	PQRY-P400YSHM-A	PQRY-P450YSHM-A	PQRY-P500YSHM-A	PQRY-P550YSHM-A	PQRY-P600YSHM-A
Heat Source unit 1	PQRY-P200YHM-A	PQRY-P250YHM-A	PQRY-P300YHM-A	PQRY-P300YHM-A	PQRY-P300YHM-A
Heat Source unit 2	PQRY-P200YHM-A	PQRY-P200YHM-A	PQRY-P250YHM-A	PQRY-P250YHM-A	PQRY-P300YHM-A
Twinning pipe Kit (optional parts)	CMY-Q100VBK				
BC controller ~	High pressure a	ø22.2		ø28.58	
Twinning pipe	Low pressure b	ø28.58		ø28.58	

Unit model	High pressure c or e	Low pressure d
P200	ø19.05	ø22.2
P250	ø19.05	ø22.2
P300	ø19.05	ø22.2

PQRY-P200,250,300YHM-A

Unit : mm[in.]

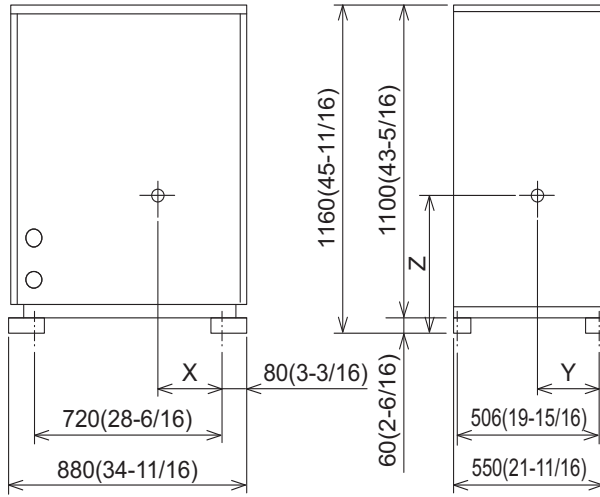

Model	X	Y	Z
PQRY-P200YHM-A	423(16-11/16)	253(10)	524(20-11/16)
PQRY-P250YHM-A	423(16-11/16)	253(10)	524(20-11/16)
PQRY-P300YHM-A	423(16-11/16)	253(10)	524(20-11/16)

PQRV-P200, 250, 300YHM-A

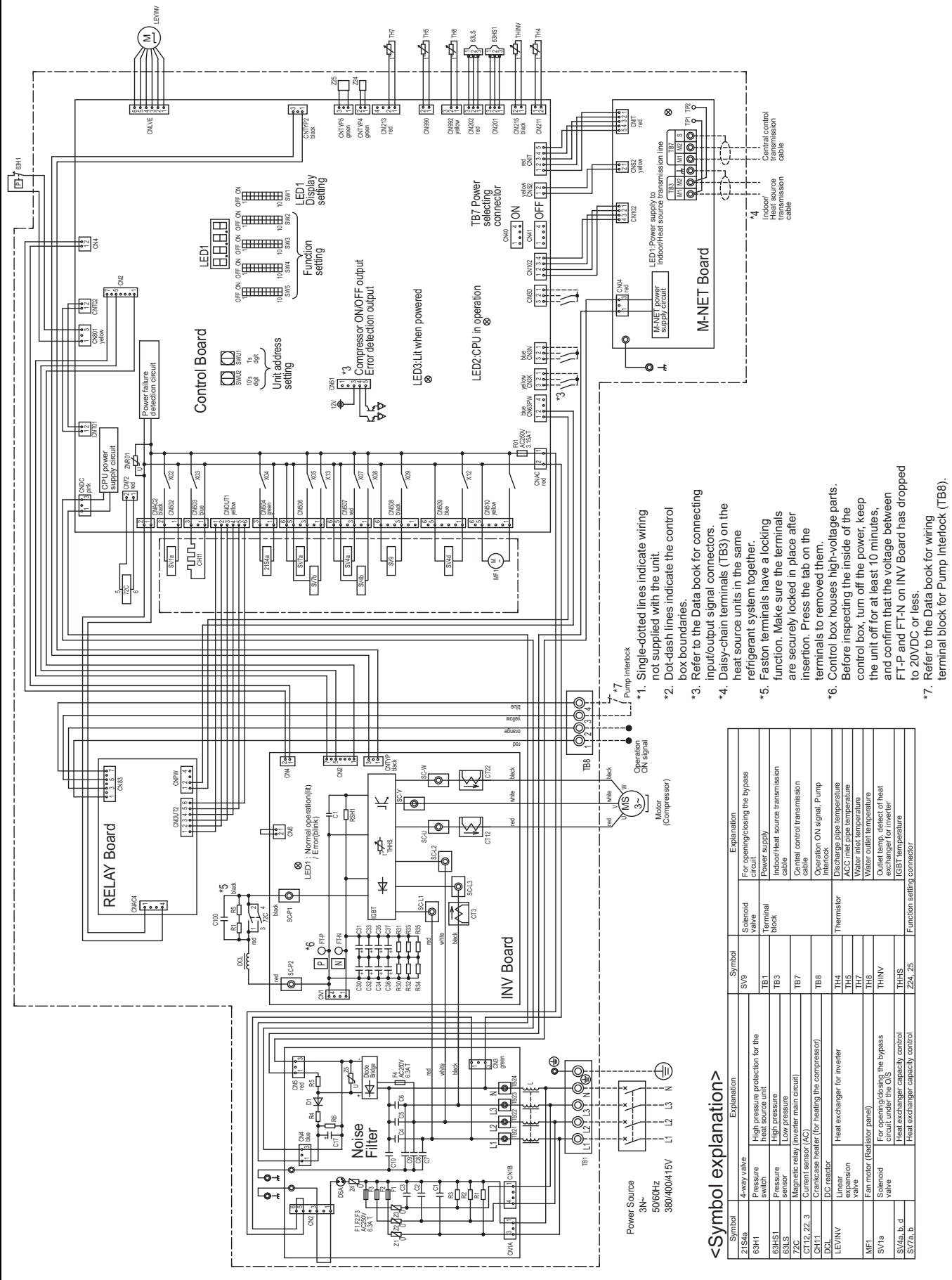

- *1. Single-dotted lines indicate wiring not supplied with the unit.
- *2. Dot-dash lines indicate the control box boundaries.
- *3. Refer to the Data book for connecting input/output signal connectors.
- *4. Daisy-chain terminals (TB3) on the heat source units in the same refrigerant system together.
- *5. Faston terminals have a locking function. Make sure the terminals are securely locked in place after insertion. Press the tab on the terminals to removed them.
- *6. Control box houses high-voltage parts. Before inspecting the inside of the control box, turn off the power, keep the unit off for at least 10 minutes, and confirm that the voltage between FT-P and FT-N on INV Board has dropped to 20VDC or less.
- *7. Refer to the Data book for wiring terminal block for Pump Interlock (TB8).

<Symbol explanation>

Symbol	Explanation	Symbol	Explanation
SV9	4-way valve	SV9	Solenoid valve
6BH1	High pressure protection for the heat source unit	TB1	Terminal block
6BHS1	Pressure	TB3	Terminal block
6BLS	High pressure	TB7	Terminal block
6BLS1	Pressure	TB8	Terminal block
6BLS2	Pressure	TH4	Thermistor
6BLS3	Pressure	TH5	Thermistor
6BLS4	Pressure	TH7	Thermistor
6BLS5	Pressure	TH8	Thermistor
6BLS6	Pressure	THIN	Thermistor
6BLS7	Pressure	THHS	Thermistor
6BLS8	Pressure	ZZ4, Z5	Function setting connector
6BLS9	Pressure		
6BLS10	Pressure		
6BLS11	Pressure		
6BLS12	Pressure		
6BLS13	Pressure		
6BLS14	Pressure		
6BLS15	Pressure		
6BLS16	Pressure		
6BLS17	Pressure		
6BLS18	Pressure		
6BLS19	Pressure		
6BLS20	Pressure		
6BLS21	Pressure		
6BLS22	Pressure		
6BLS23	Pressure		
6BLS24	Pressure		
6BLS25	Pressure		
6BLS26	Pressure		
6BLS27	Pressure		
6BLS28	Pressure		
6BLS29	Pressure		
6BLS30	Pressure		
6BLS31	Pressure		
6BLS32	Pressure		
6BLS33	Pressure		
6BLS34	Pressure		
6BLS35	Pressure		
6BLS36	Pressure		
6BLS37	Pressure		
6BLS38	Pressure		
6BLS39	Pressure		
6BLS40	Pressure		
6BLS41	Pressure		
6BLS42	Pressure		
6BLS43	Pressure		
6BLS44	Pressure		
6BLS45	Pressure		
6BLS46	Pressure		
6BLS47	Pressure		
6BLS48	Pressure		
6BLS49	Pressure		
6BLS50	Pressure		

WR2

Measurement condition
PQRY-P200,250,300YHM-A

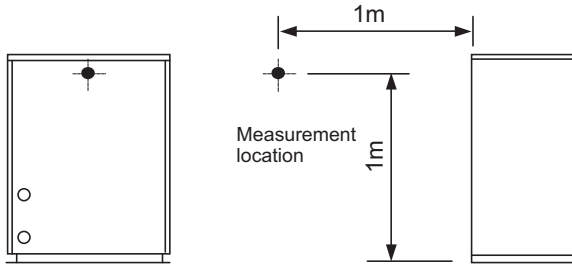

Sound level of PQRY-P300YHM-A

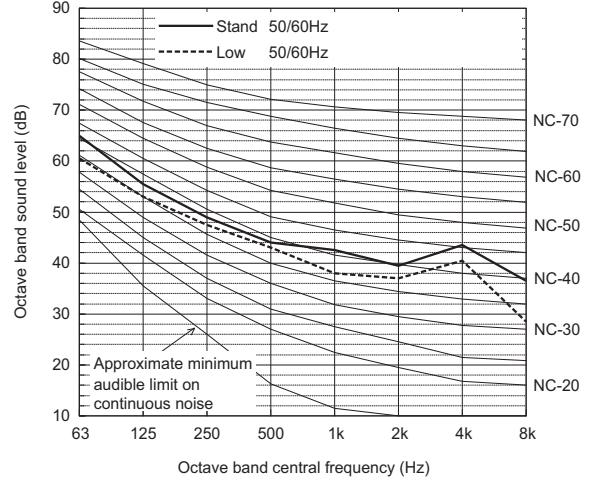

		63	125	250	500	1k	2k	4k	8k	dB(A)
Standard	50/60Hz	65.0	55.5	49.0	44.0	42.5	39.5	43.5	36.5	50.0
Low noise mode	50/60Hz	60.5	53.0	47.5	43.0	38.0	37.0	40.5	28.5	47.0

When Low noise mode is set, the A/C system's capacity is limited. The system could return to normal operation from Low noise mode automatically in the case that the operation condition is severe.

Sound level of PQRY-P200YHM-A

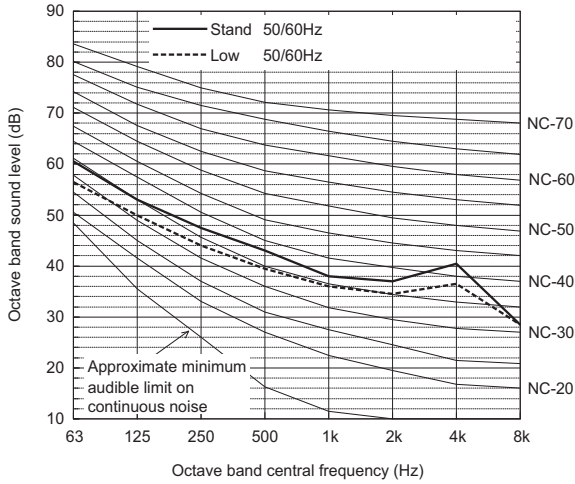

		63	125	250	500	1k	2k	4k	8k	dB(A)
Standard	50/60Hz	60.5	53.0	47.5	43.0	38.0	37.0	40.5	28.5	47.0
Low noise mode	50/60Hz	56.5	50.0	44.0	39.5	36.0	34.5	36.5	28.5	44.0

When Low noise mode is set, the A/C system's capacity is limited. The system could return to normal operation from Low noise mode automatically in the case that the operation condition is severe.

Sound level of PQRY-P250YHM-A

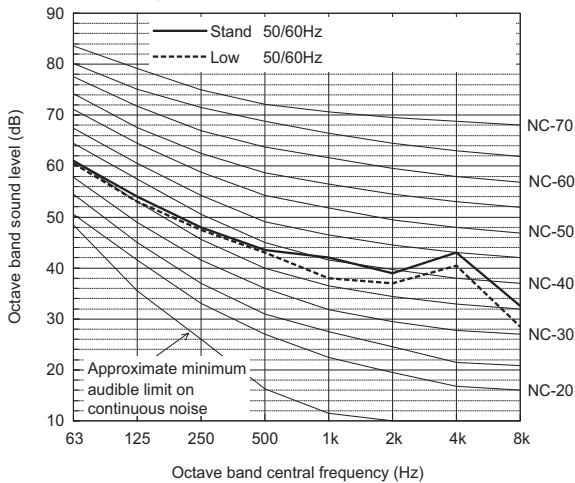

		63	125	250	500	1k	2k	4k	8k	dB(A)
Standard	50/60Hz	61.0	54.0	48.0	43.5	42.0	39.0	43.0	32.5	49.0
Low noise mode	50/60Hz	60.5	53.0	47.5	43.0	38.0	37.0	40.5	28.5	47.0

When Low noise mode is set, the A/C system's capacity is limited. The system could return to normal operation from Low noise mode automatically in the case that the operation condition is severe.

Measurement condition
PQRY-P400,450,500,550,600YSHM-A

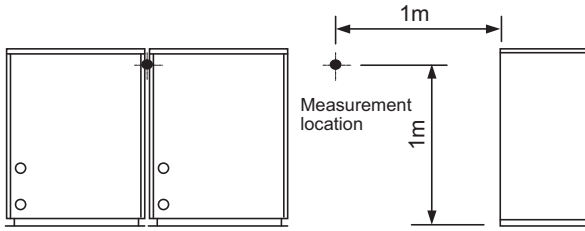

Sound level of PQRY-P500YSHM-A

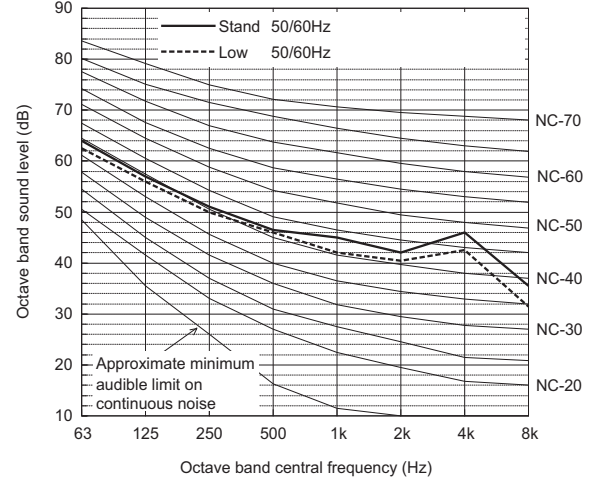

		63	125	250	500	1k	2k	4k	8k	dB(A)
Standard	50/60Hz	64.0	57.0	51.0	46.5	45.0	42.0	46.0	35.5	52.0
Low noise mode	50/60Hz	62.5	56.0	50.0	46.0	42.0	40.5	42.5	31.5	50.0

When Low noise mode is set, the A/C system's capacity is limited. The system could return to normal operation from Low noise mode automatically in the case that the operation condition is severe.

Sound level of PQRY-P400YSHM-A

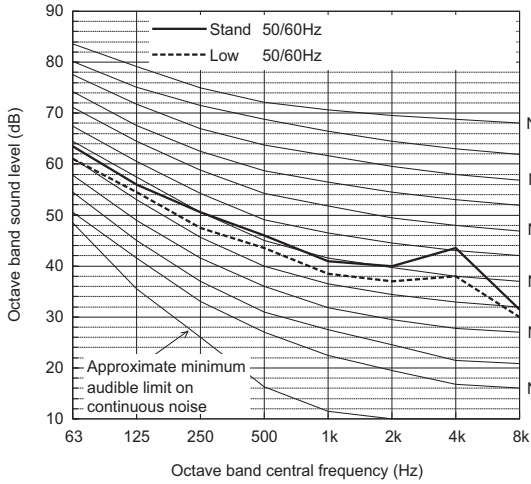

		63	125	250	500	1k	2k	4k	8k	dB(A)
Standard	50/60Hz	63.5	56.0	50.5	46.0	41.0	40.0	43.5	31.5	50.0
Low noise mode	50/60Hz	61.0	54.5	47.5	43.5	38.5	37.0	38.0	30.0	47.0

When Low noise mode is set, the A/C system's capacity is limited. The system could return to normal operation from Low noise mode automatically in the case that the operation condition is severe.

Sound level of PQRY-P550YSHM-A

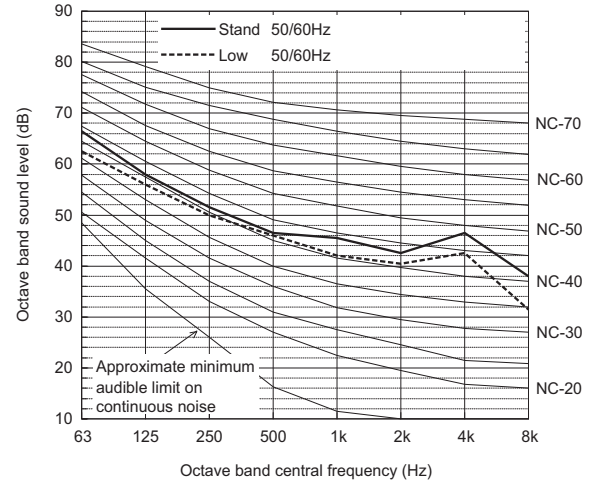

		63	125	250	500	1k	2k	4k	8k	dB(A)
Standard	50/60Hz	66.5	58.0	51.5	46.5	45.5	42.5	46.5	38.0	52.5
Low noise mode	50/60Hz	62.5	56.0	50.0	46.0	42.0	40.5	42.5	31.5	50.0

When Low noise mode is set, the A/C system's capacity is limited. The system could return to normal operation from Low noise mode automatically in the case that the operation condition is severe.

Sound level of PQRY-P450YSHM-A

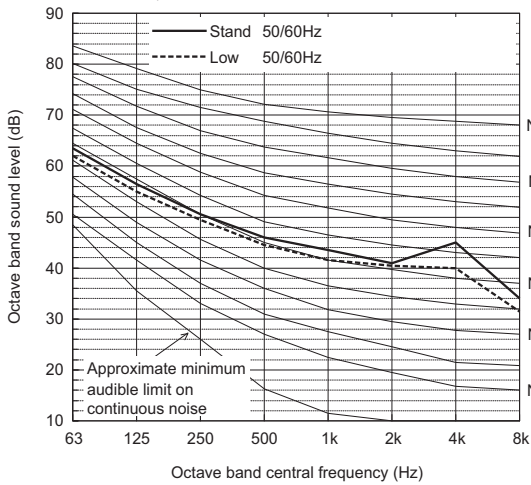

		63	125	250	500	1k	2k	4k	8k	dB(A)
Standard	50/60Hz	63.5	56.5	50.5	46.0	43.5	41.0	45.0	34.0	51.0
Low noise mode	50/60Hz	62.0	55.0	49.5	44.5	41.5	40.5	40.0	31.5	49.0

When Low noise mode is set, the A/C system's capacity is limited. The system could return to normal operation from Low noise mode automatically in the case that the operation condition is severe.

Sound level of PQRY-P600YSHM-A

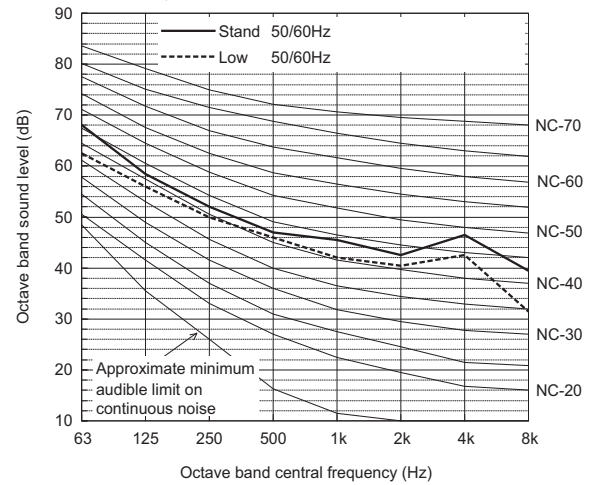

		63	125	250	500	1k	2k	4k	8k	dB(A)
Standard	50/60Hz	68.0	58.5	52.0	47.0	45.5	42.5	46.5	39.5	53.0
Low noise mode	50/60Hz	62.5	56.0	50.0	46.0	42.0	40.5	42.5	31.5	50.0

When Low noise mode is set, the A/C system's capacity is limited. The system could return to normal operation from Low noise mode automatically in the case that the operation condition is severe.

WR2

6-1. Correction by temperature

CITY MULTI could have various capacities at different designing temperatures. Using the nominal cooling/heating capacity values and the ratios below, the capacity can be found for various temperatures.

		PQHY-P200YHM-A	PQRY-P200YHM-A
Nominal Cooling Capacity	kW	22.4	22.4
	BTU/h	76,400	76,400
Input	kW	3.92	3.96

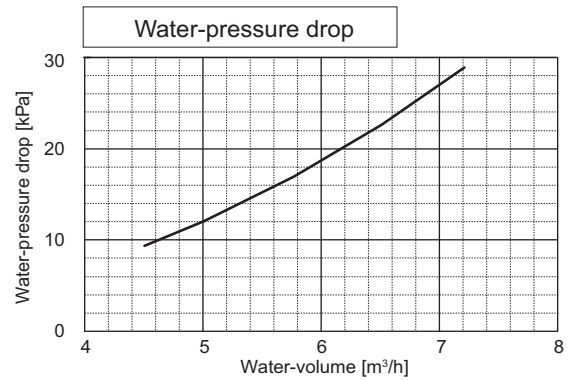
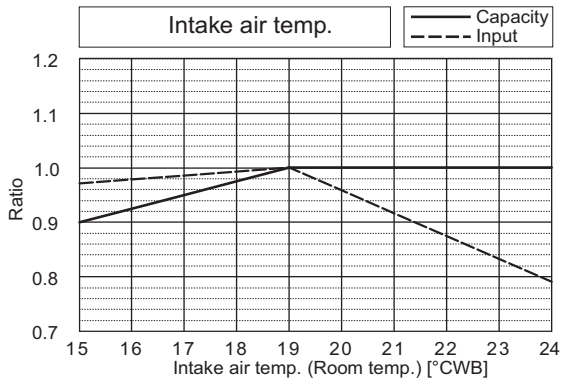
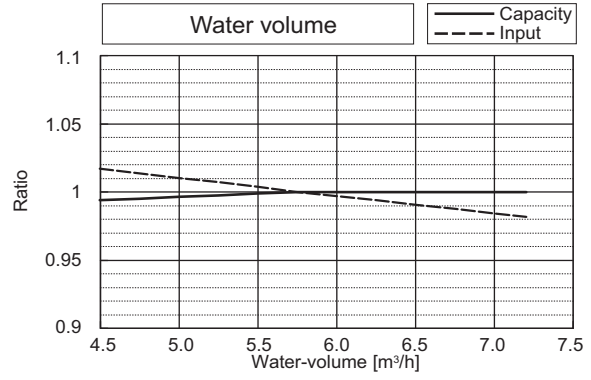
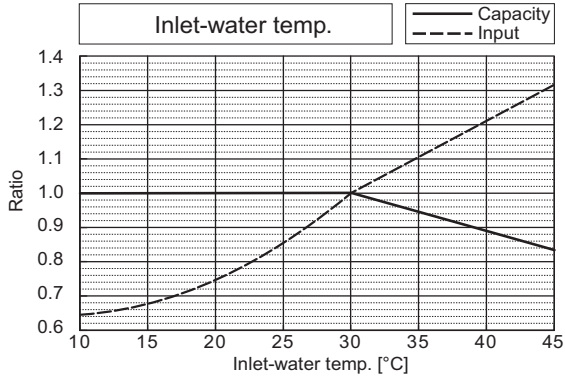

		PQHY-P200YHM-A	PQRY-P200YHM-A
Nominal Heating Capacity	kW	25.0	25.0
	BTU/h	85,300	85,300
Input	kW	4.12	4.12

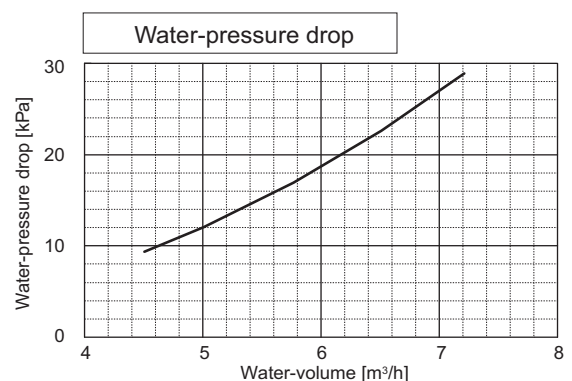
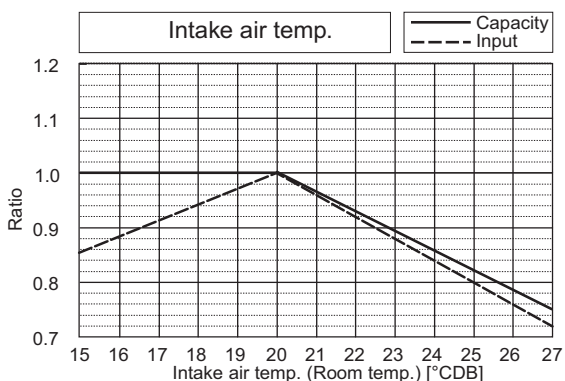
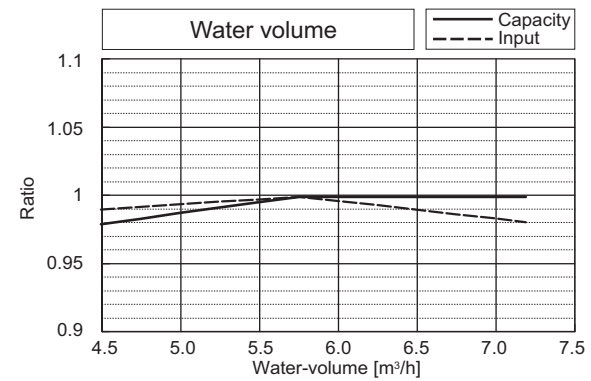
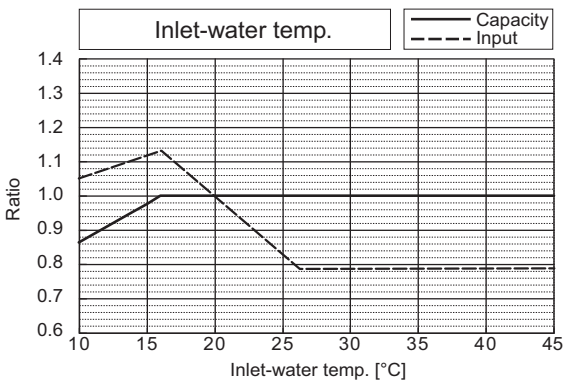

WR2

6. CAPACITY TABLES

		PQHY-P250YHM-A	PQRY-P250YHM-A
Nominal Cooling Capacity	kW	28.0	28.0
	BTU/h	95,500	95,500
Input	kW	5.45	5.51

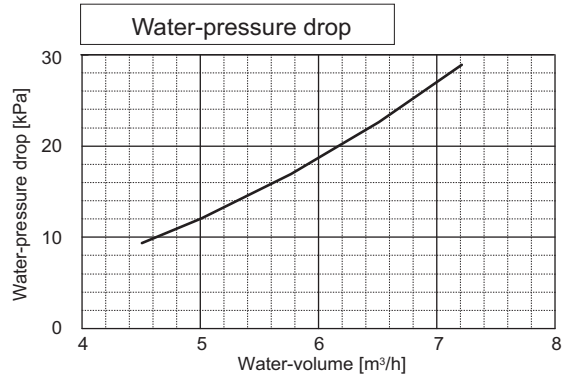
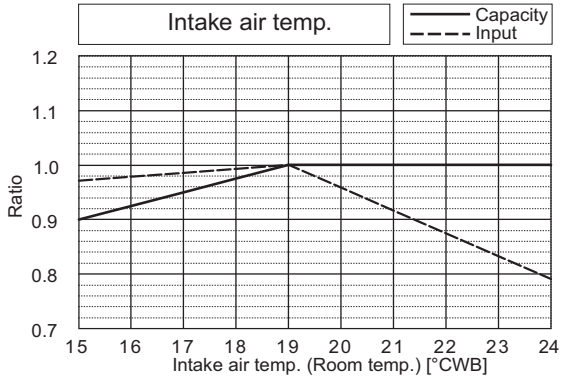
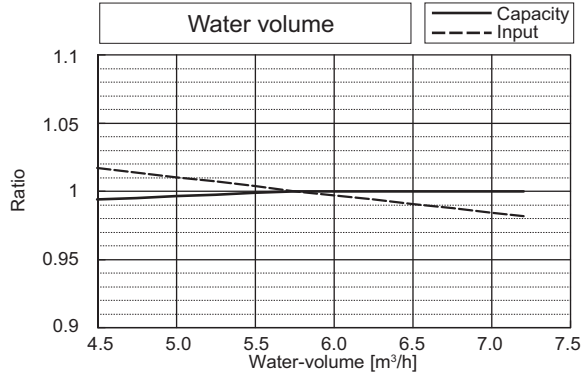
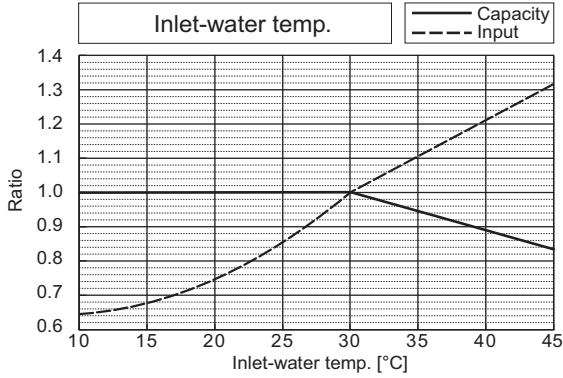

		PQHY-P250YHM-A	PQRY-P250YHM-A
Nominal Heating Capacity	kW	31.5	31.5
	BTU/h	107,500	107,500
Input	kW	5.80	5.80

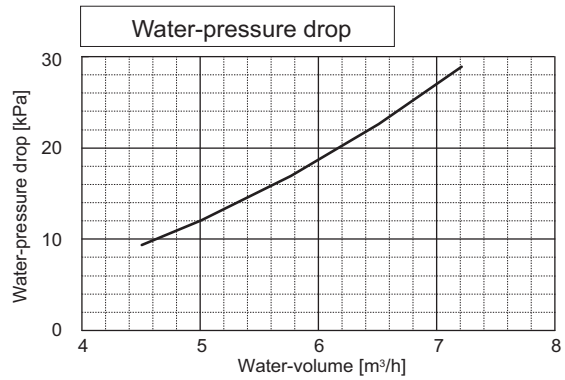
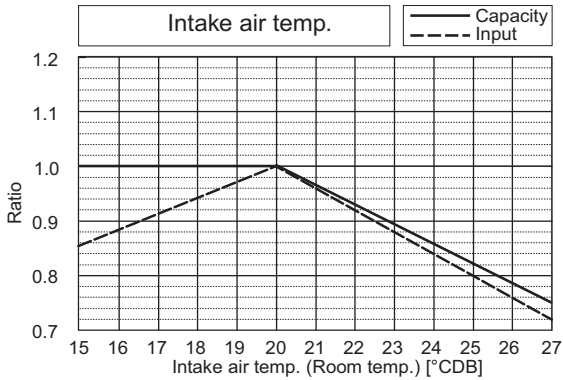
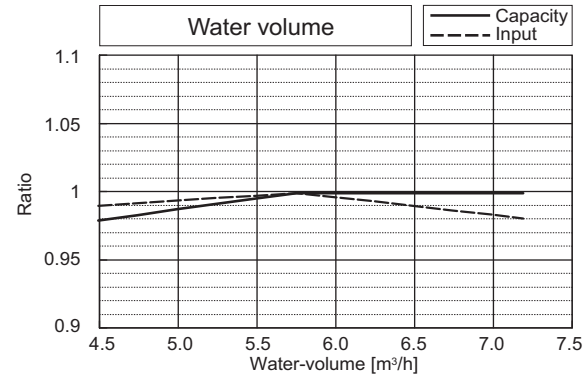
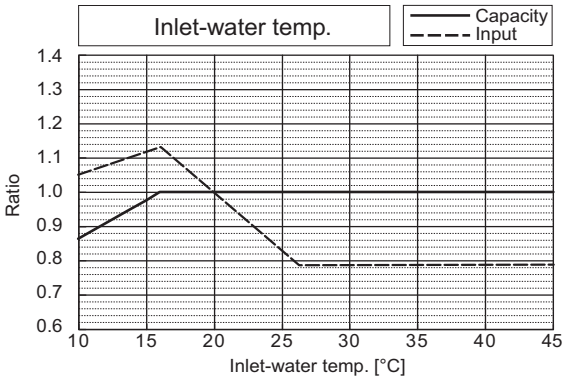

WR2

6. CAPACITY TABLES

		PQHY-P300YHM-A	PQRY-P300YHM-A
Nominal Cooling Capacity	kW	33.5	33.5
	BTU/h	114,300	114,300
Input	kW	7.36	7.44

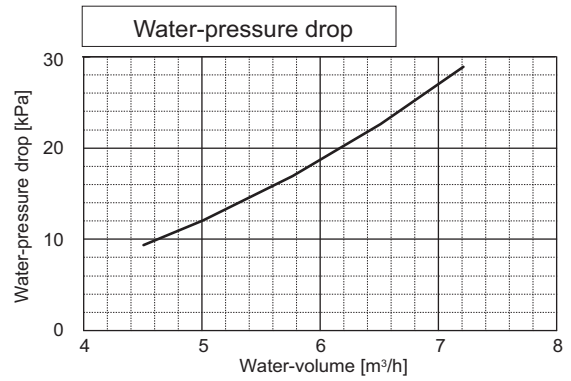
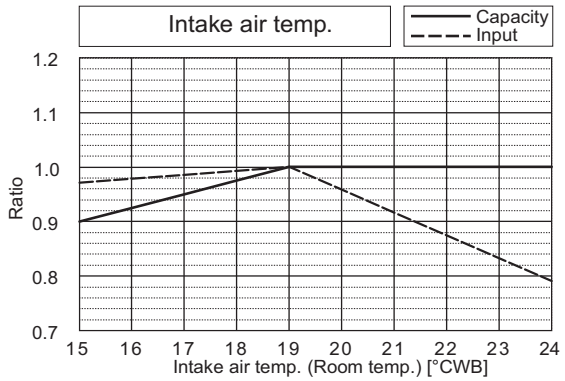
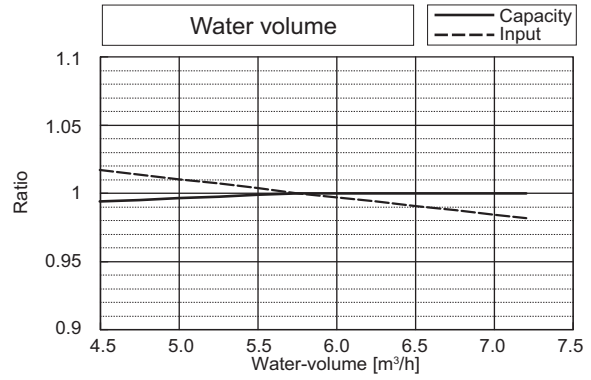
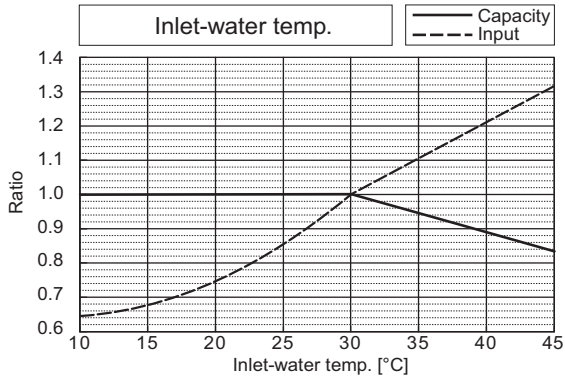

		PQHY-P300YHM-A	PQRY-P300YHM-A
Nominal Heating Capacity	kW	37.5	37.5
	BTU/h	128,000	128,000
Input	kW	8.15	8.15

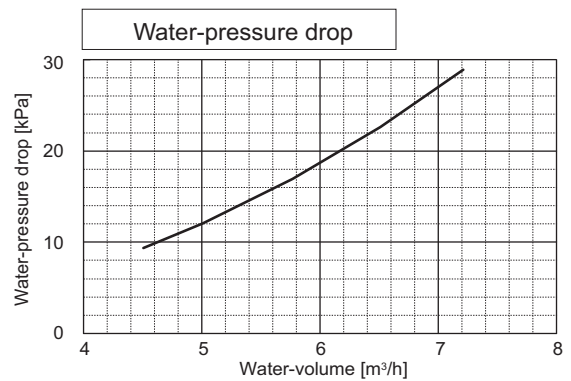
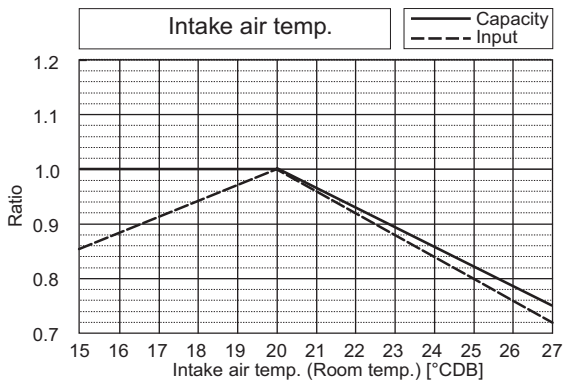
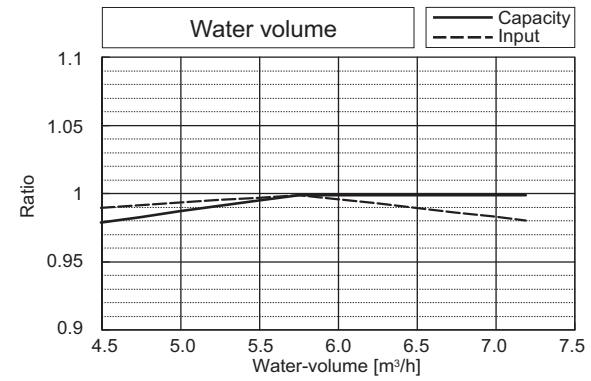
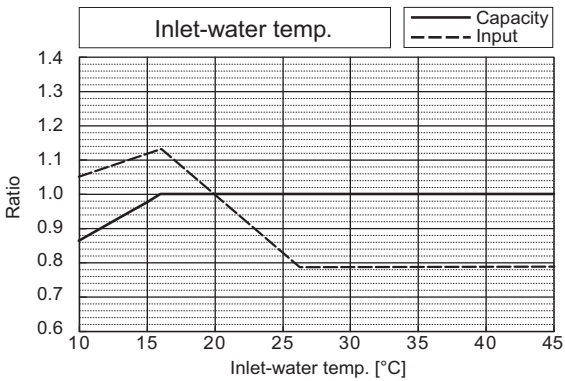

WR2

6. CAPACITY TABLES

		PQHY-P400YSHM-A	PQRY-P400YSHM-A
Nominal Cooling Capacity	kW	45.0	45.0
	BTU/h	153,500	153,500
Input	kW	8.25	8.32

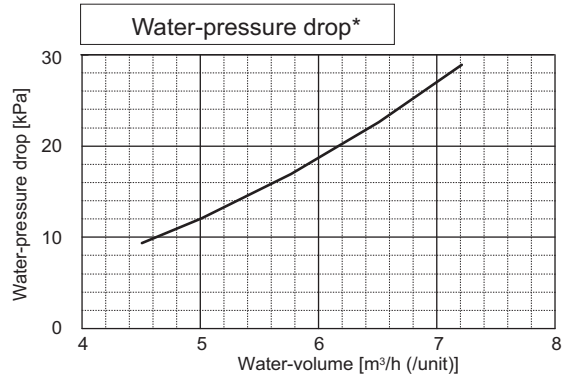
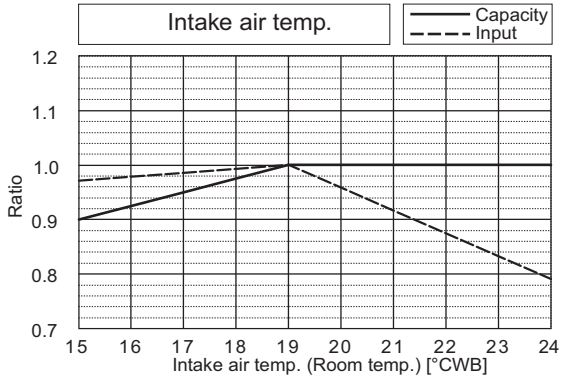
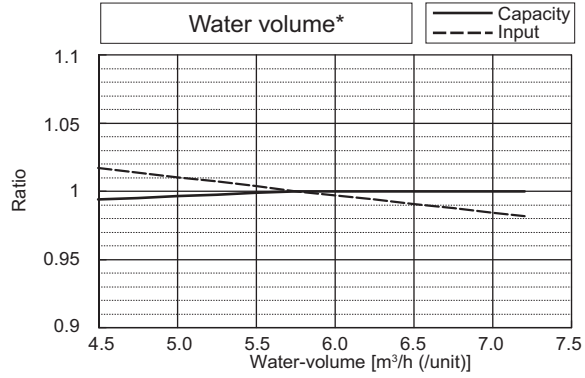
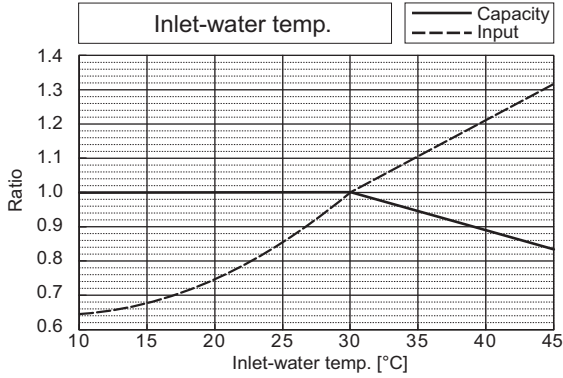

*The drawing indicates characteristic per unit.

		PQHY-P400YSHM-A	PQRY-P400YSHM-A
Nominal Heating Capacity	kW	50.0	50.0
	BTU/h	170,600	170,600
Input	kW	8.65	8.65

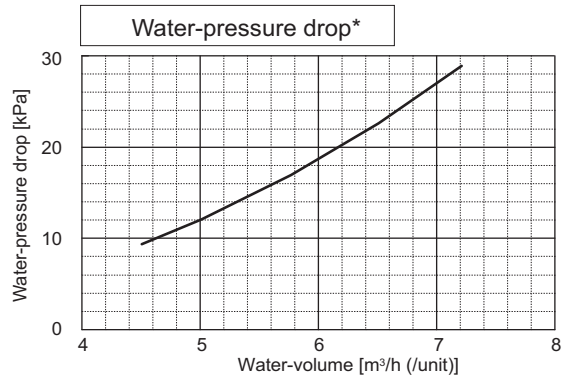
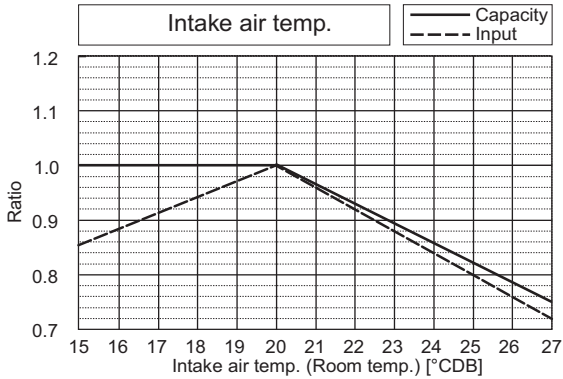
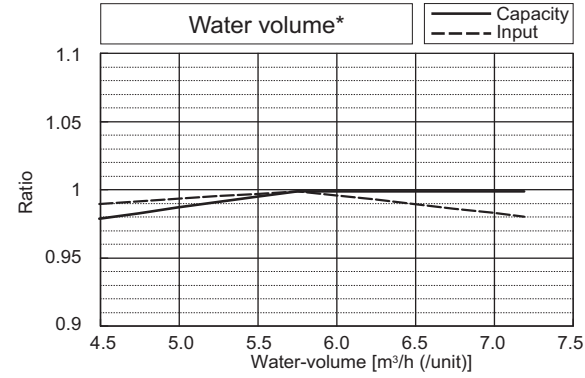
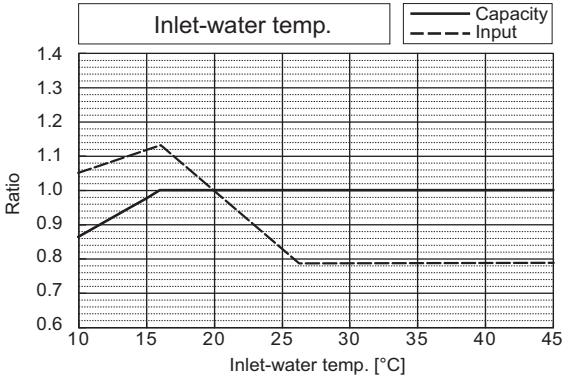

*The drawing indicates characteristic per unit.

WR2

6. CAPACITY TABLES

		PQHY-P450YSHM-A	PQRY-P450YSHM-A
Nominal Cooling Capacity	kW	50.0	50.0
	BTU/h	170,600	170,600
Input	kW	9.84	9.94

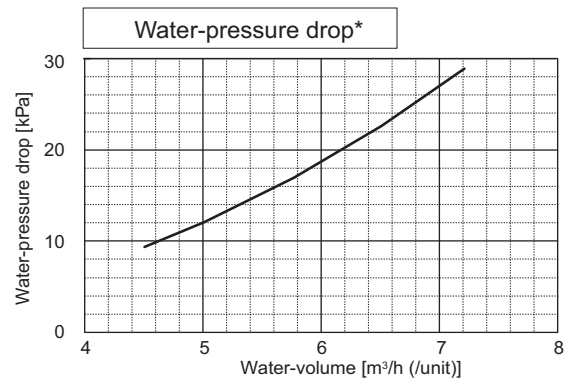
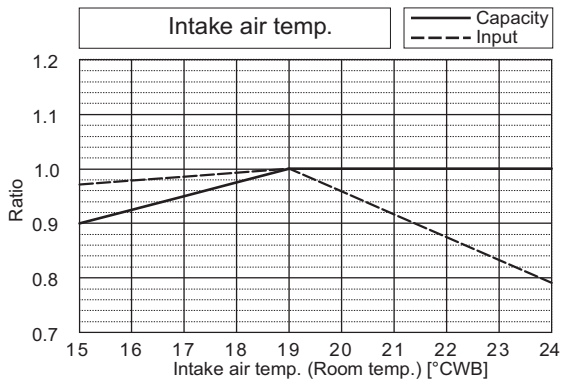
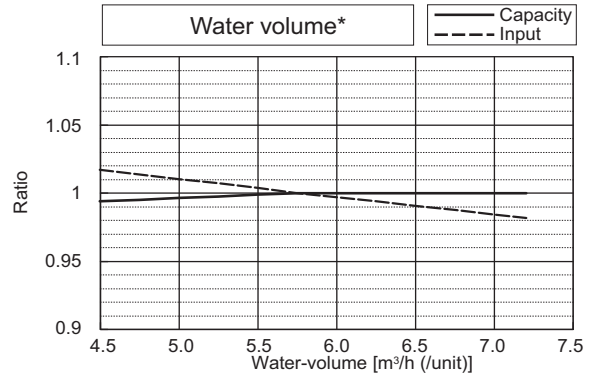
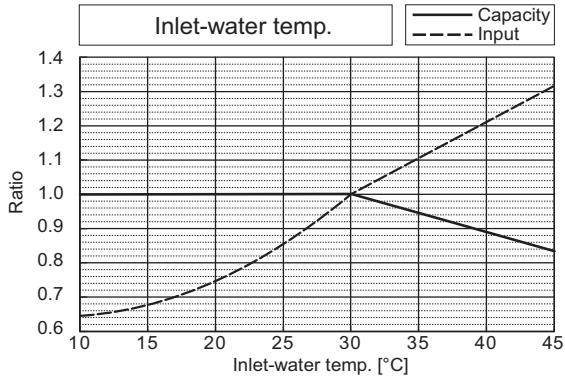

		PQHY-P450YSHM-A	PQRY-P450YSHM-A
Nominal Heating Capacity	kW	56.0	56.0
	BTU/h	191,100	191,100
Input	kW	10.42	10.42

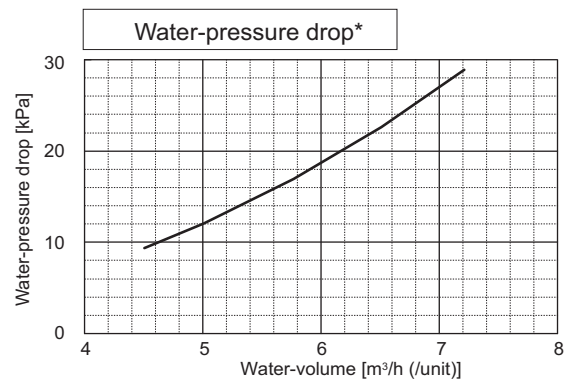
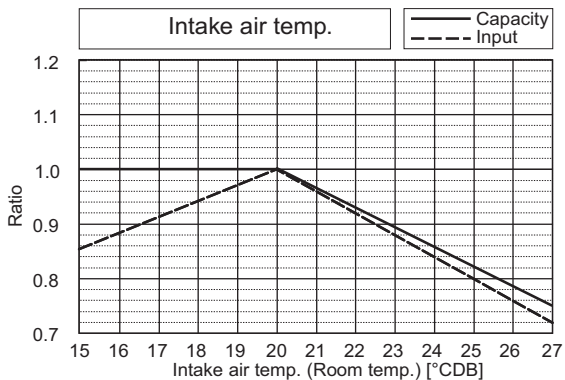
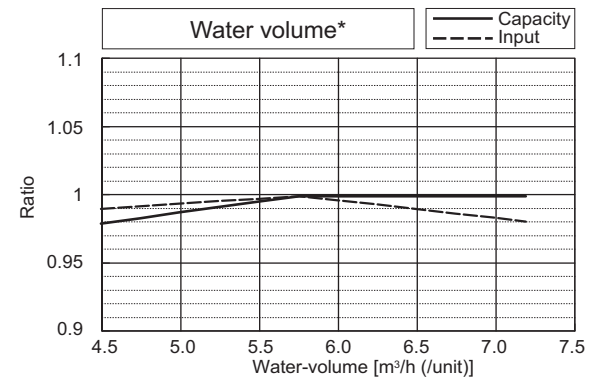
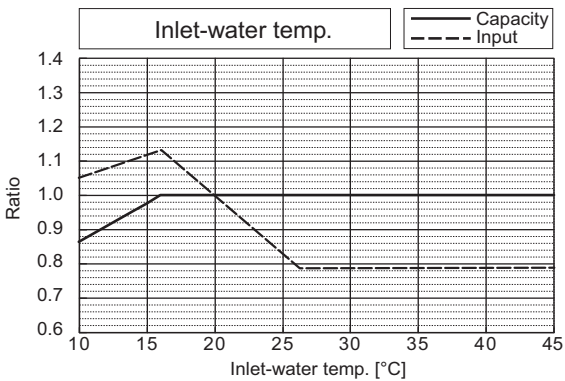

WR2

6. CAPACITY TABLES

		PQHY-P500YSHM-A	PQRY-P500YSHM-A
Nominal Cooling Capacity	kW	56.0	56.0
	BTU/h	191,100	191,100
Input	kW	11.45	11.57

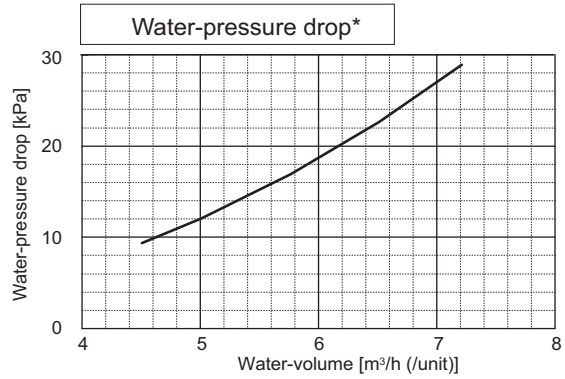
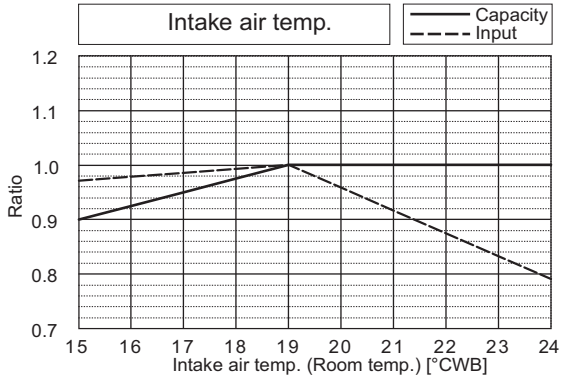
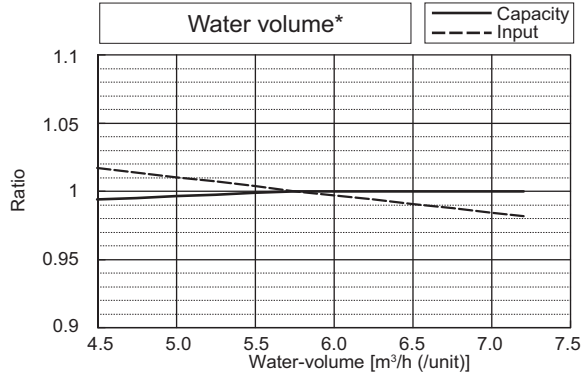
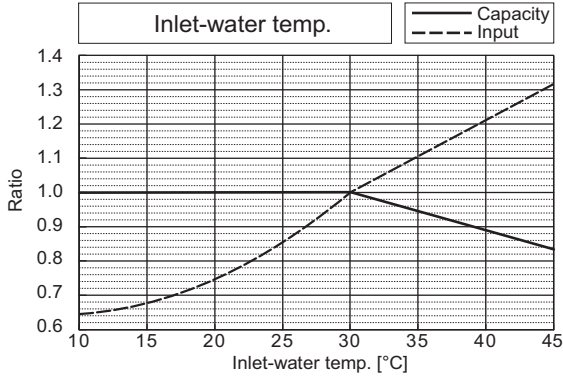

*The drawing indicates characteristic per unit.

		PQHY-P500YSHM-A	PQRY-P500YSHM-A
Nominal Heating Capacity	kW	63.0	63.0
	BTU/h	215,000	215,000
Input	kW	12.06	12.06

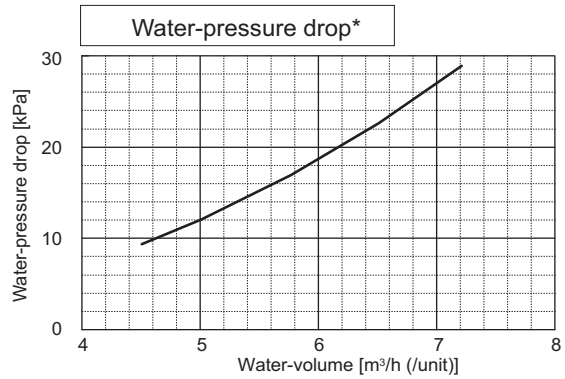
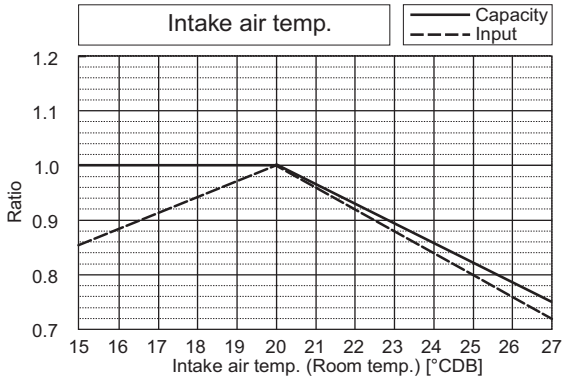
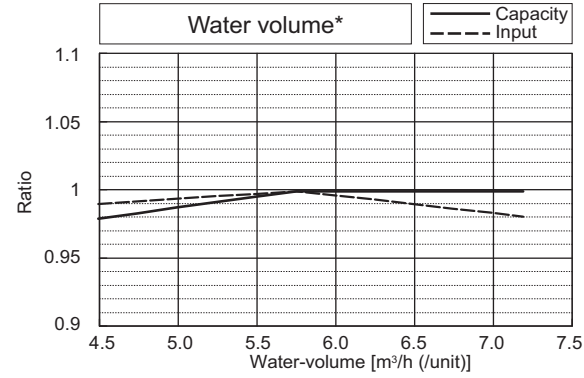
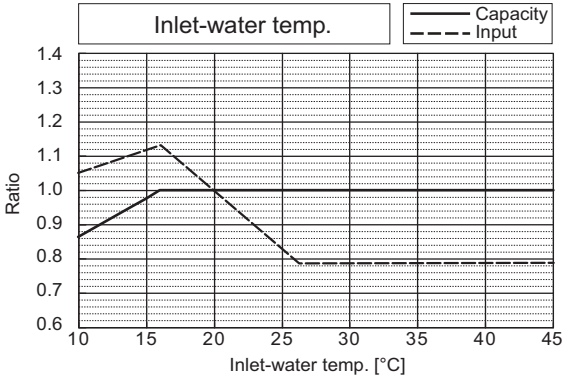

*The drawing indicates characteristic per unit.

WR2

6. CAPACITY TABLES

		PQHY-P550YSHM-A	PQRY-P550YSHM-A
Nominal Cooling Capacity	kW	63.0	63.0
	BTU/h	215,000	215,000
Input	kW	13.46	13.60

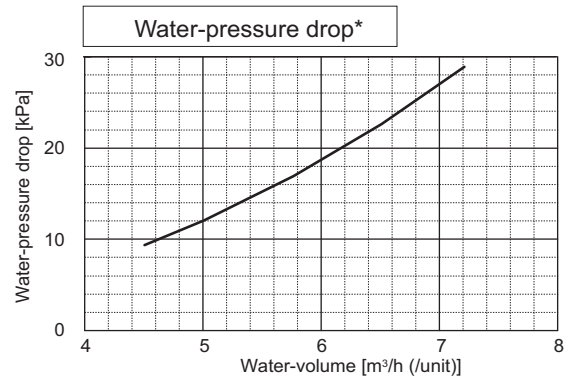
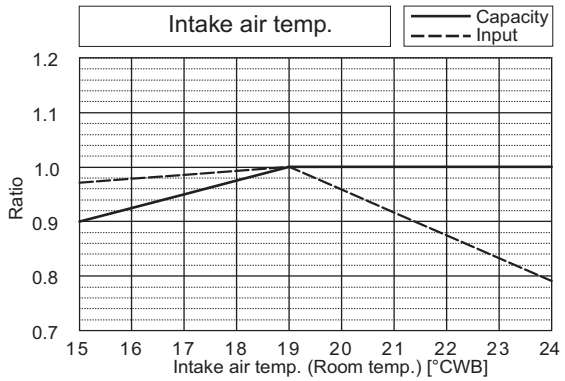
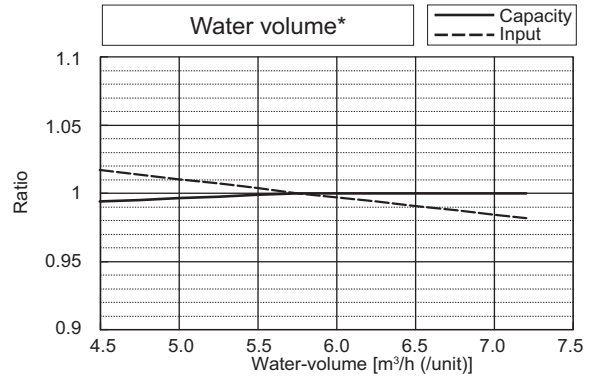
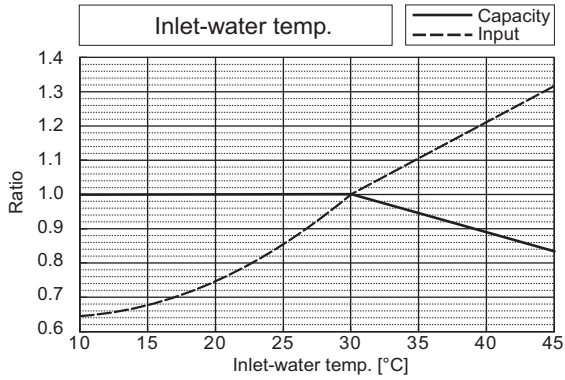

*The drawing indicates characteristic per unit.

		PQHY-P550YSHM-A	PQRY-P550YSHM-A
Nominal Heating Capacity	kW	69.0	69.0
	BTU/h	235,400	235,400
Input	kW	14.65	14.65

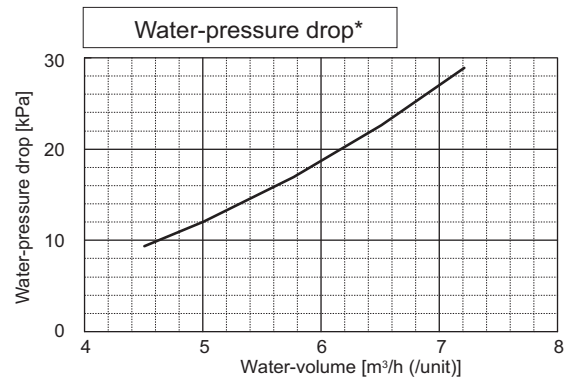
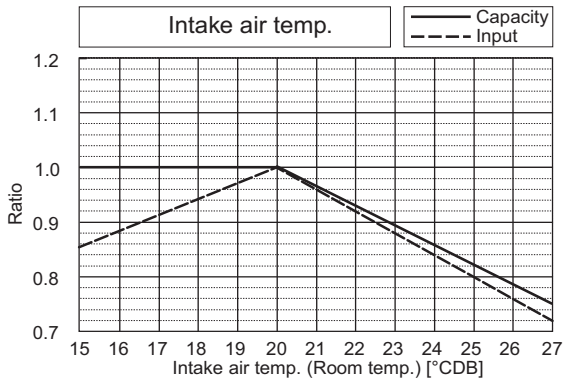
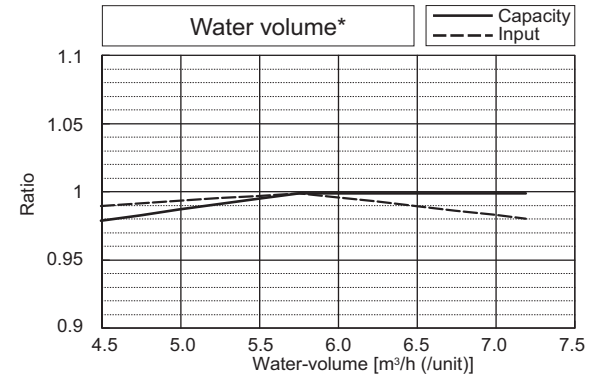
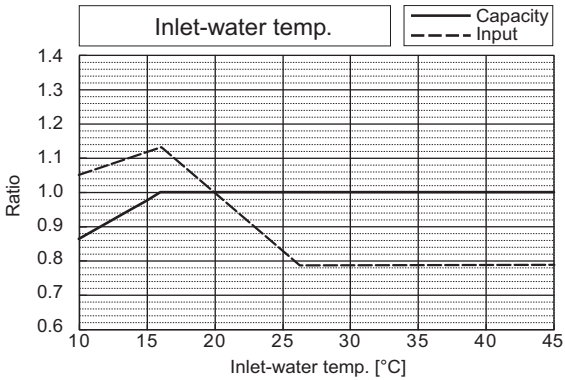

*The drawing indicates characteristic per unit.

WR2

6. CAPACITY TABLES

		PQHY-P600YSHM-A	PQRY-P600YSHM-A
Nominal Cooling Capacity	kW	69.0	69.0
	BTU/h	235,400	235,400
Input	kW	15.48	15.62

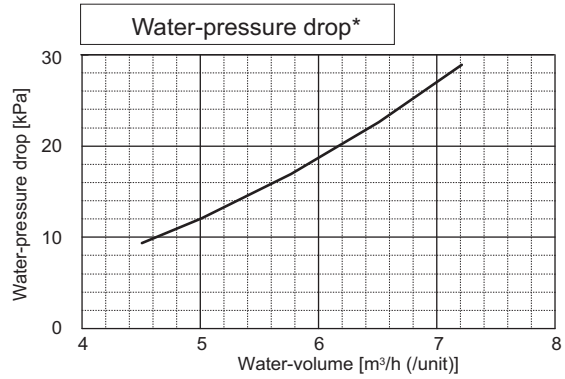
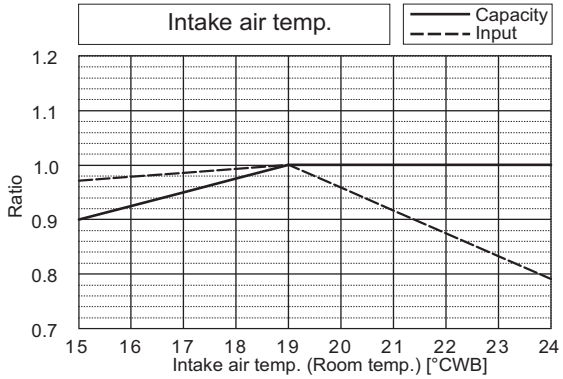
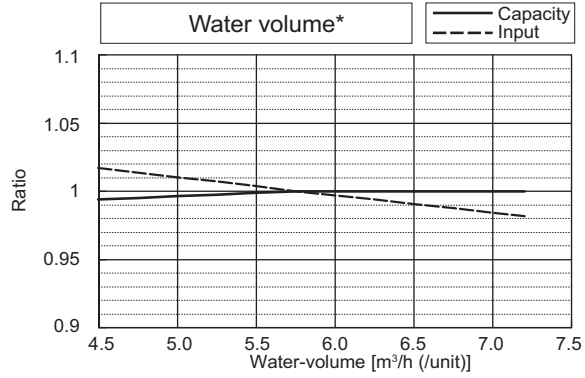
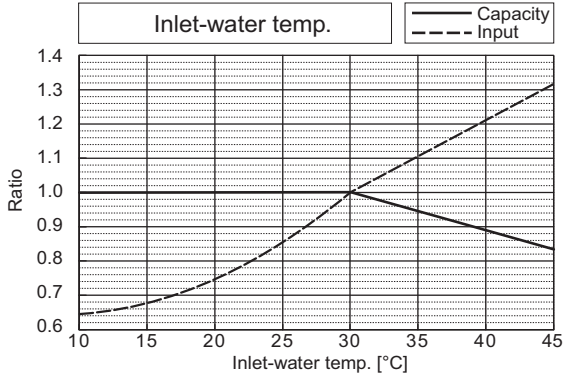

*The drawing indicates characteristic per unit.

		PQHY-P600YSHM-A	PQRY-P600YSHM-A
Nominal Heating Capacity	kW	76.5	76.5
	BTU/h	261,000	261,000
Input	kW	17.12	17.12

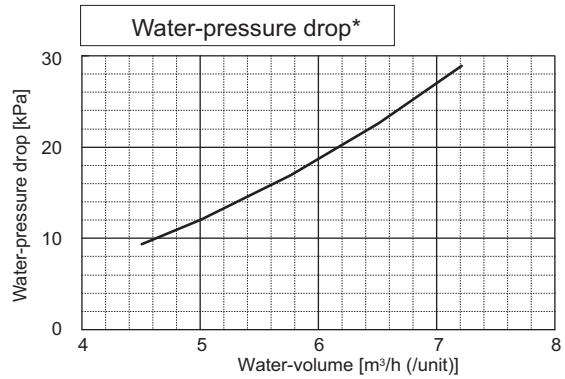
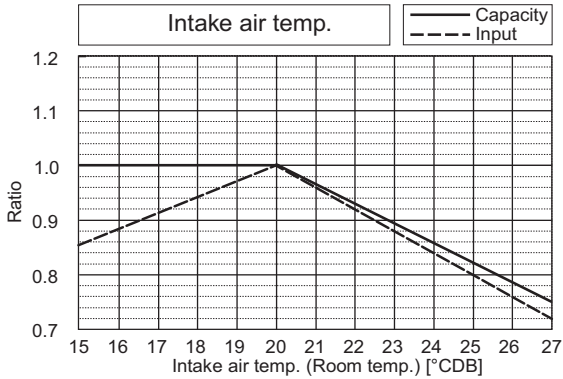
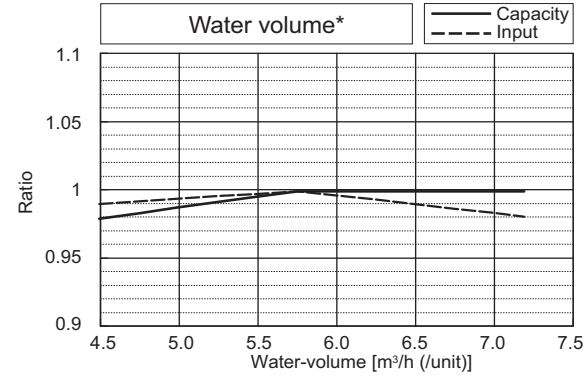
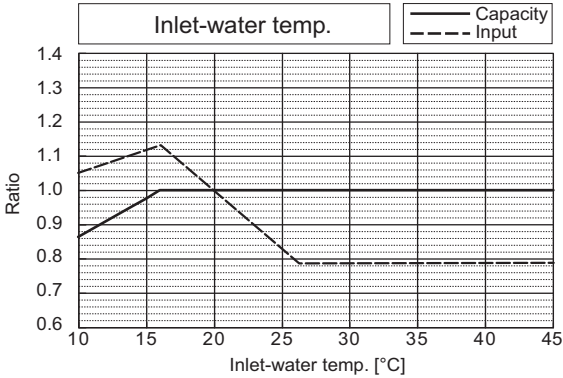

*The drawing indicates characteristic per unit.

WR2

6-2. Correction by total indoor

CITY MULTI system have different capacities and inputs when many combinations of indoor units with different total capacities are connected. Using following tables, the maximum capacity can be found to ensure the system is installed with enough capacity for a particular application.

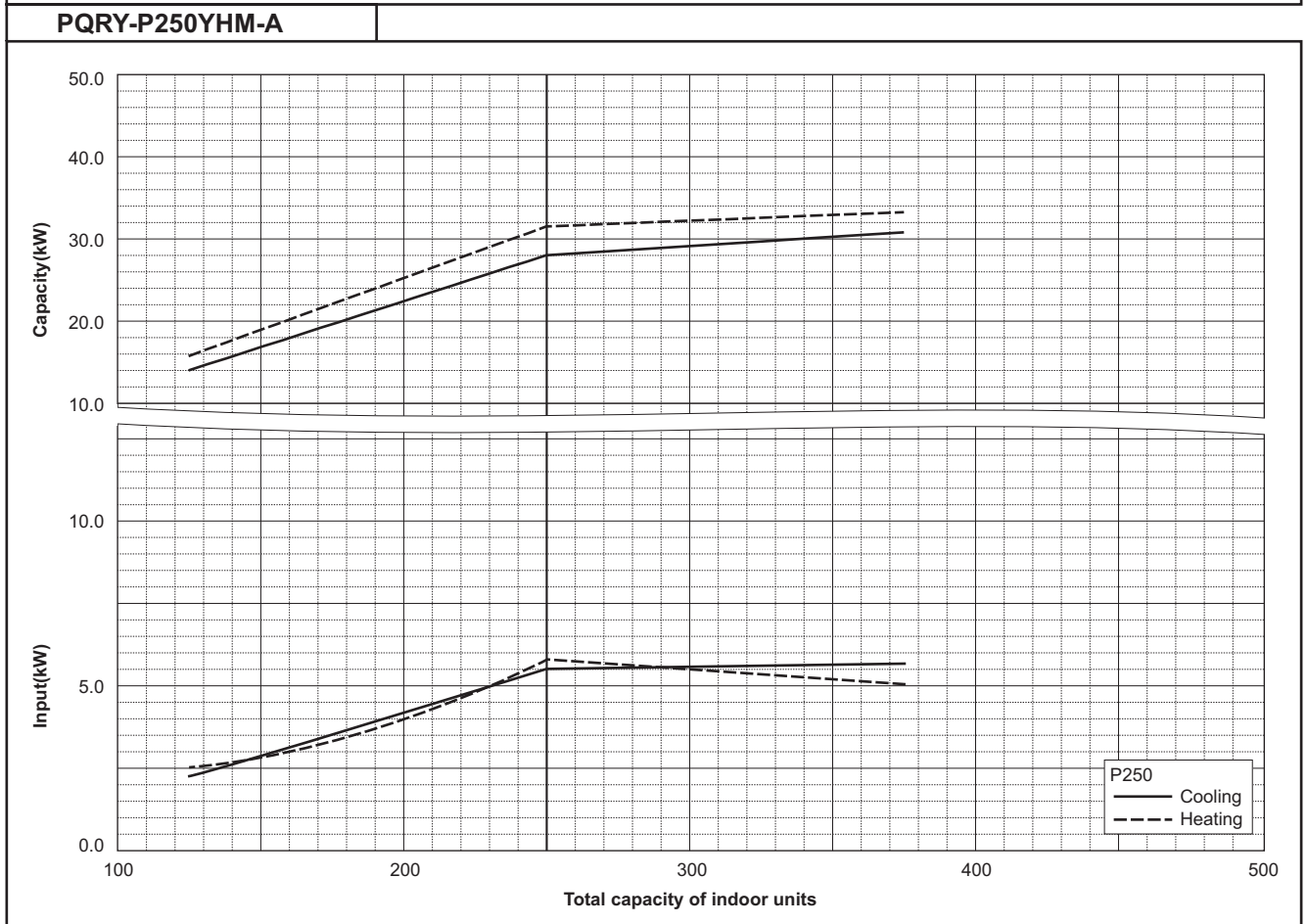
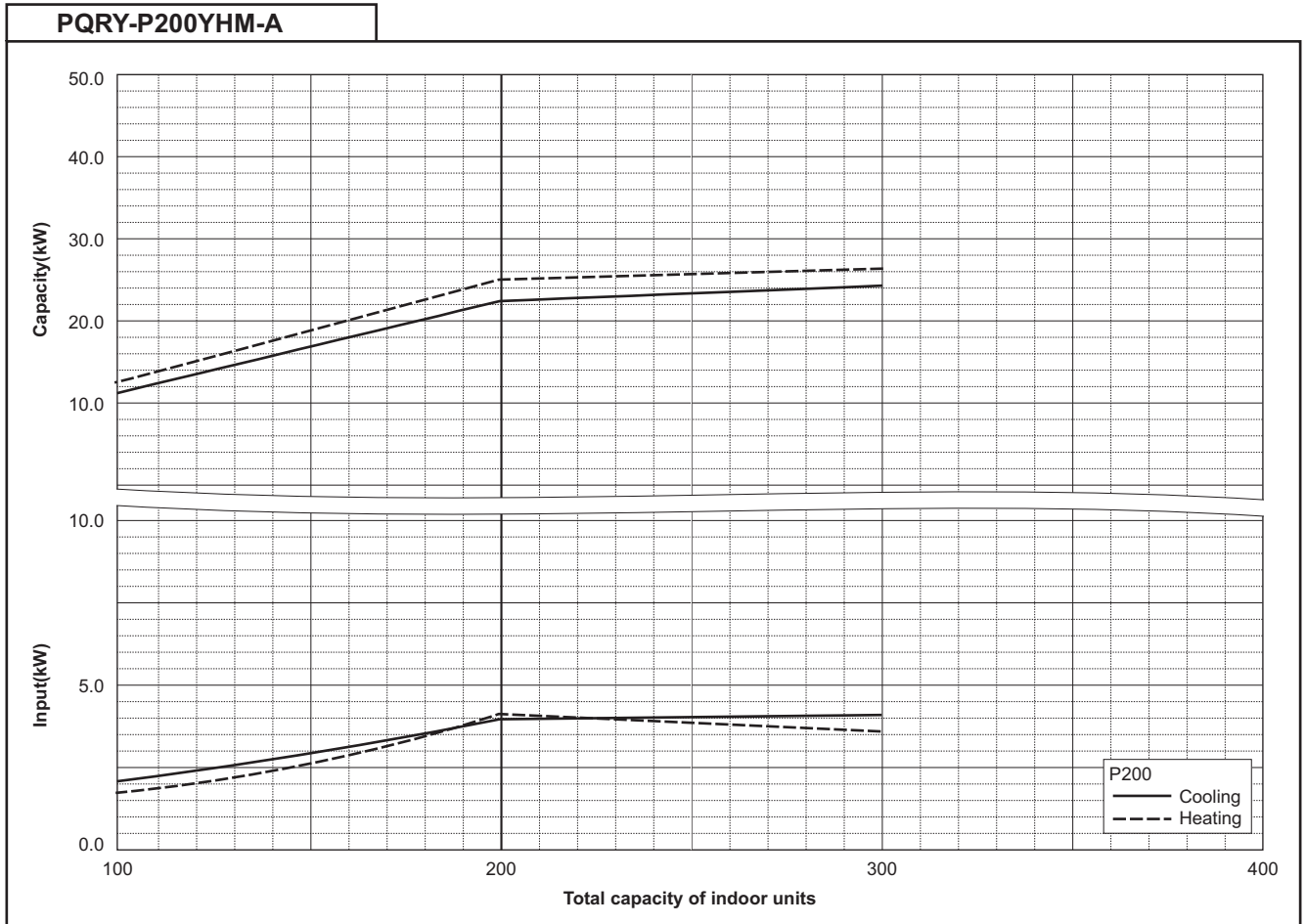

WR2

6. CAPACITY TABLES

G10 2nd

PQRY-P300YHM-A

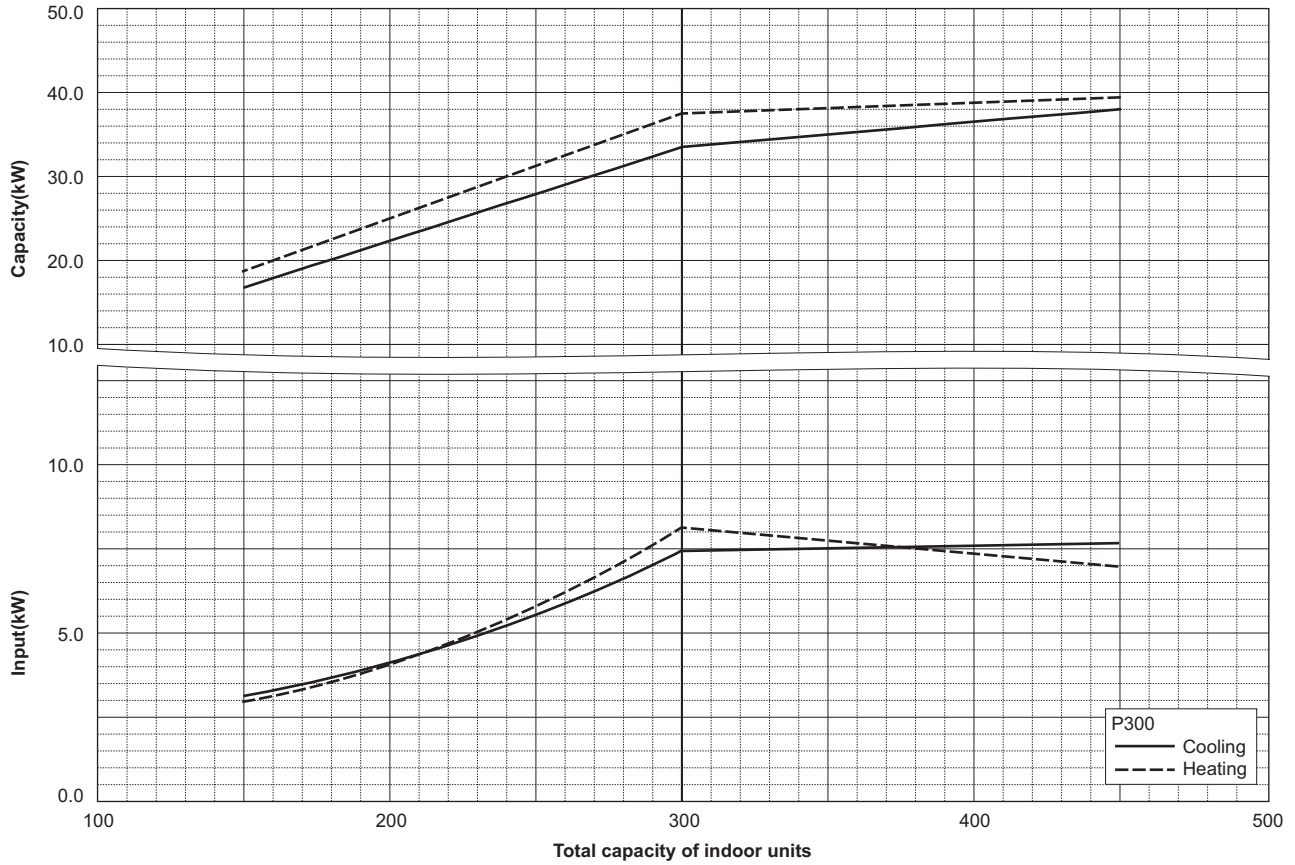

PQRY-P400YSHM-A

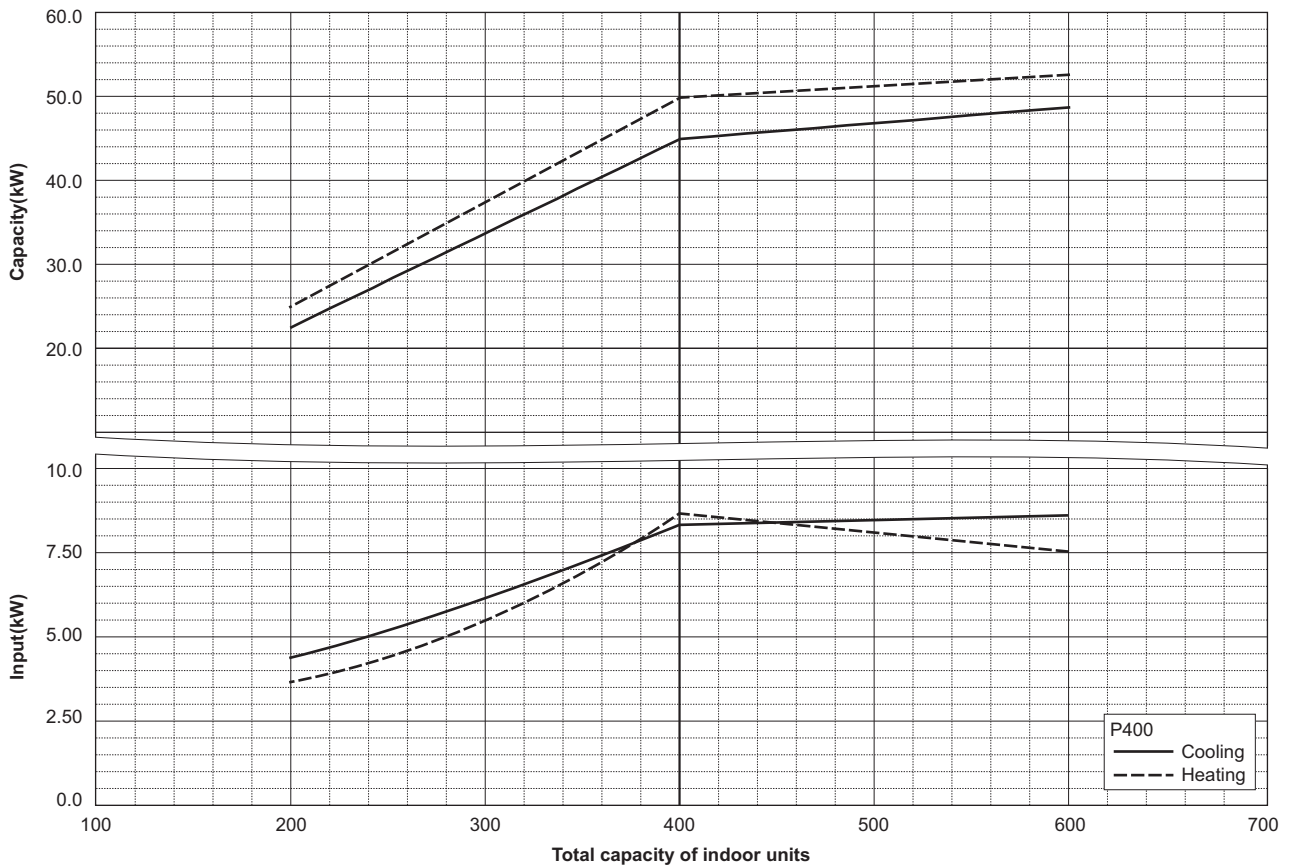

WR2

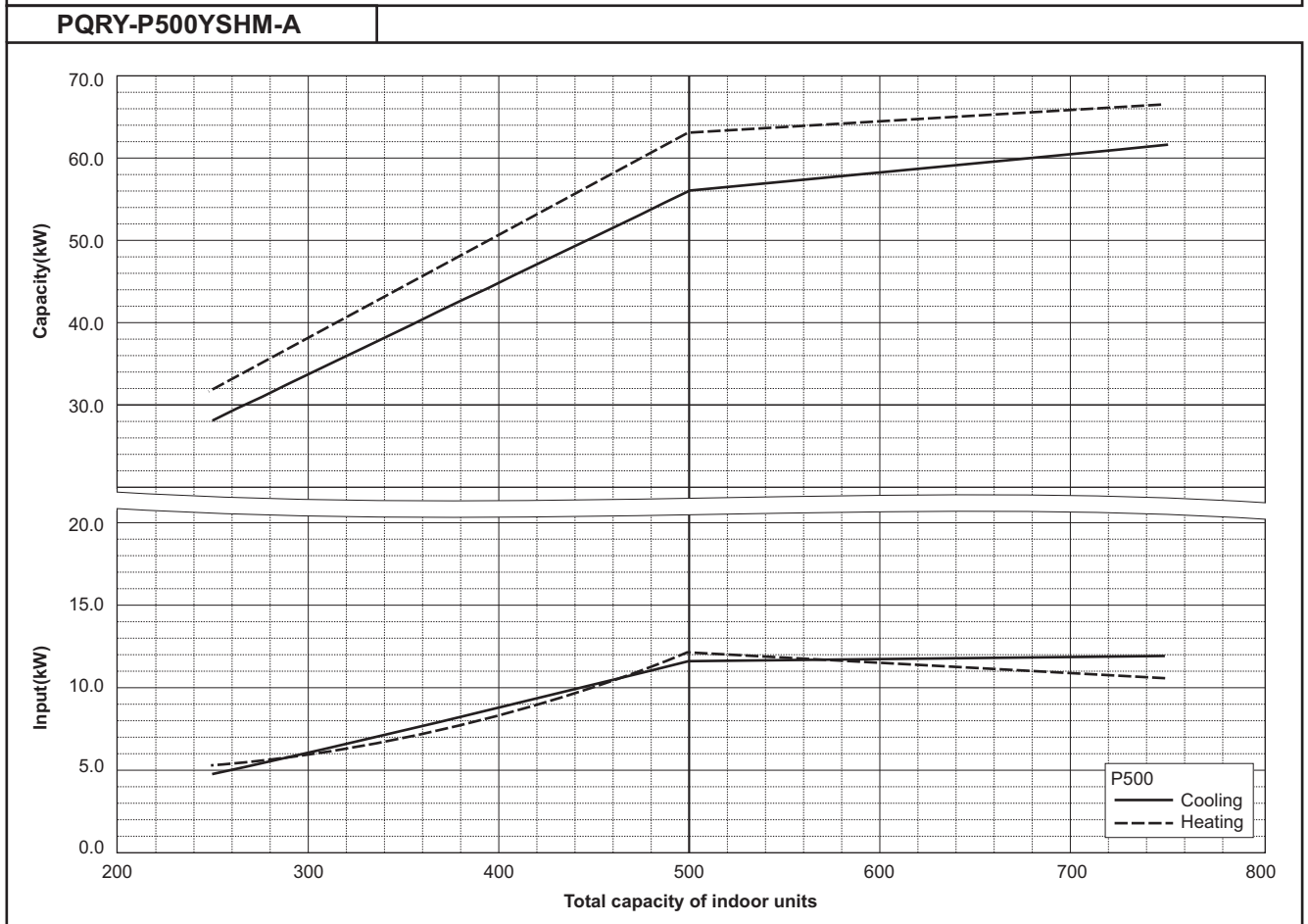
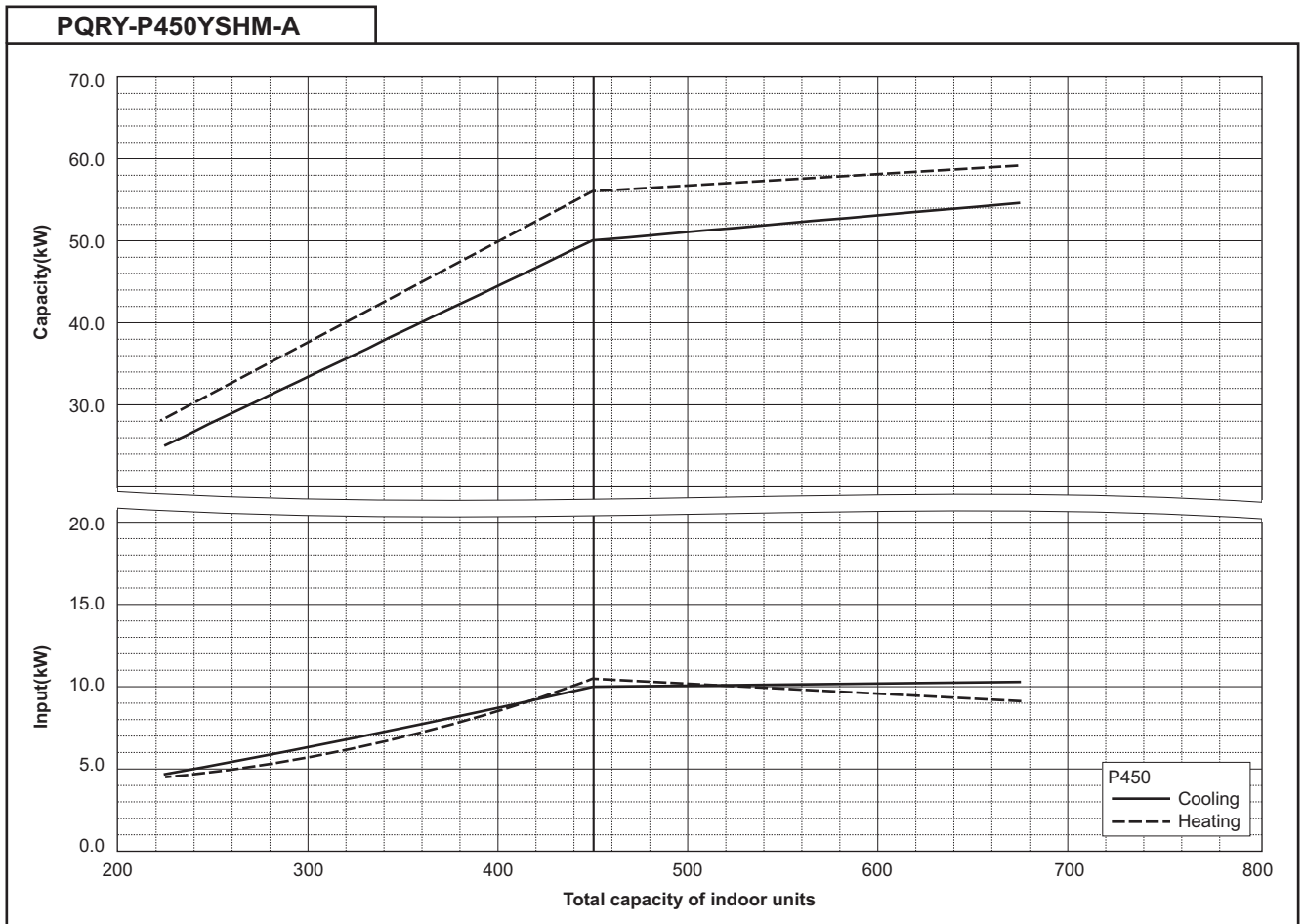

WR2

6. CAPACITY TABLES

PQRY-P550YSHM-A

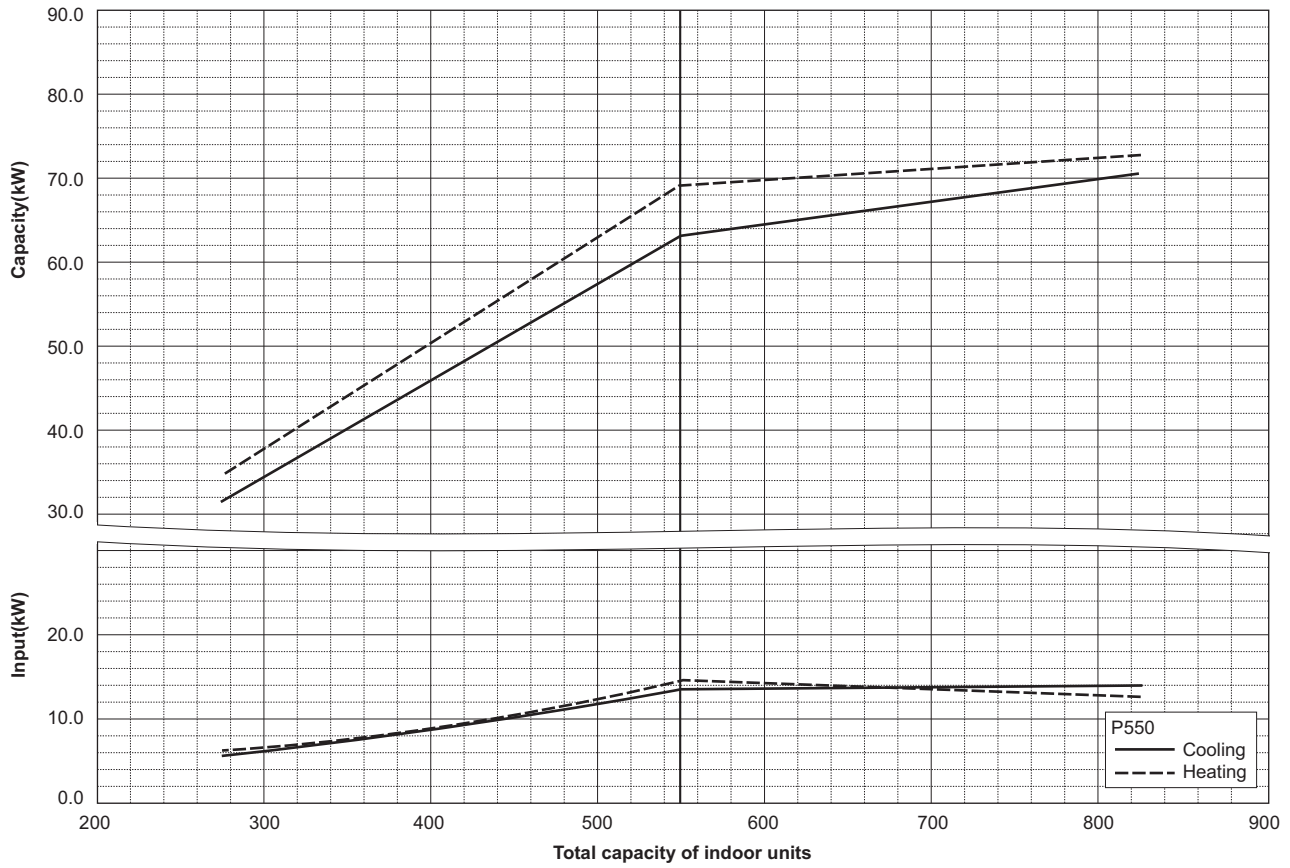

PQRY-P600YSHM-A

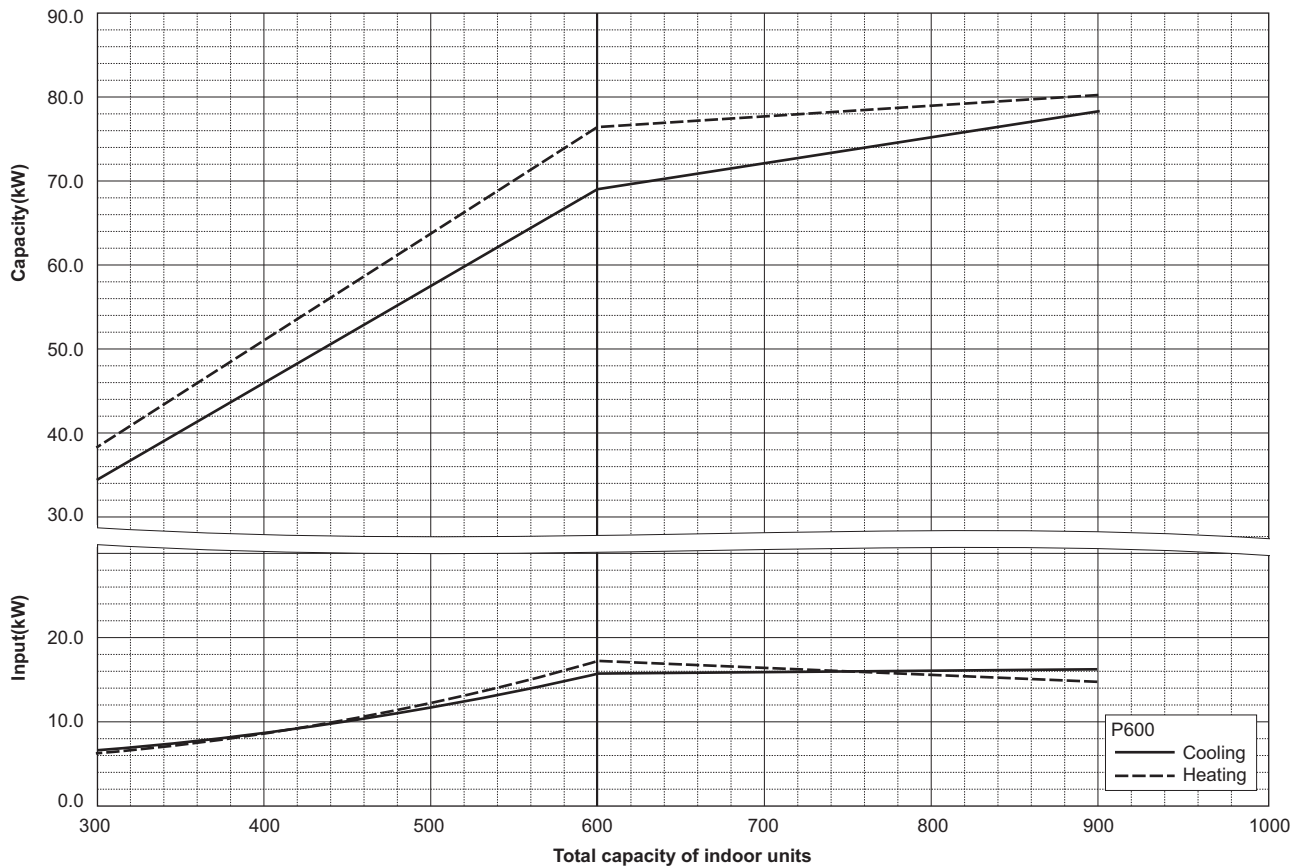

WR2

6-3. Correction by refrigerant piping length

CITY MULTI systems can have extended piping lengths if certain limitations are followed, but cooling/heating capacity could be reduced. Using following correction factor by equivalent piping length shown at 6-3-1 and 6-3-2, capacity can be found. 6-3-3 shows how to obtain the equivalent piping length.

6-3-1. Cooling capacity correction

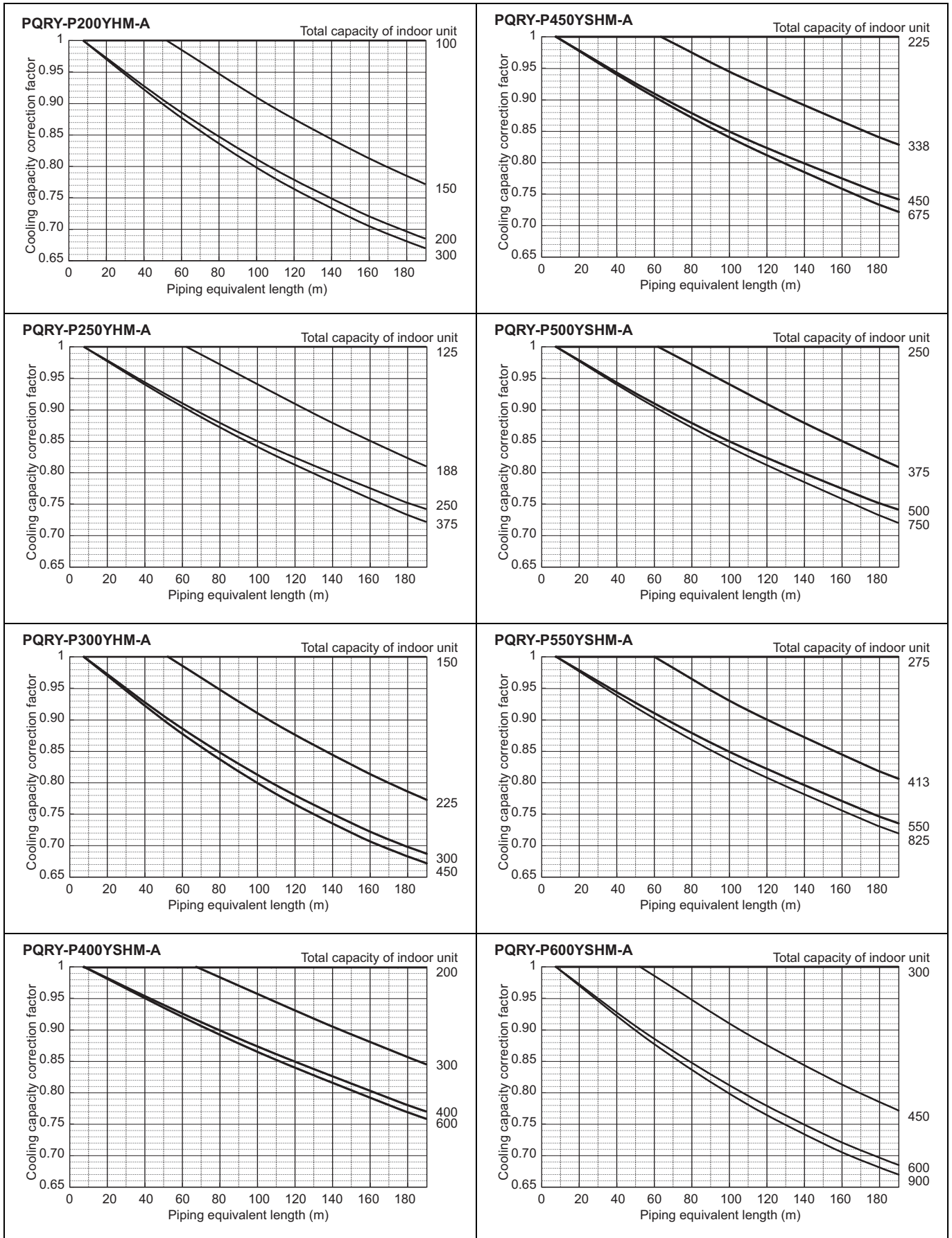

6-3-2. Heating capacity correction

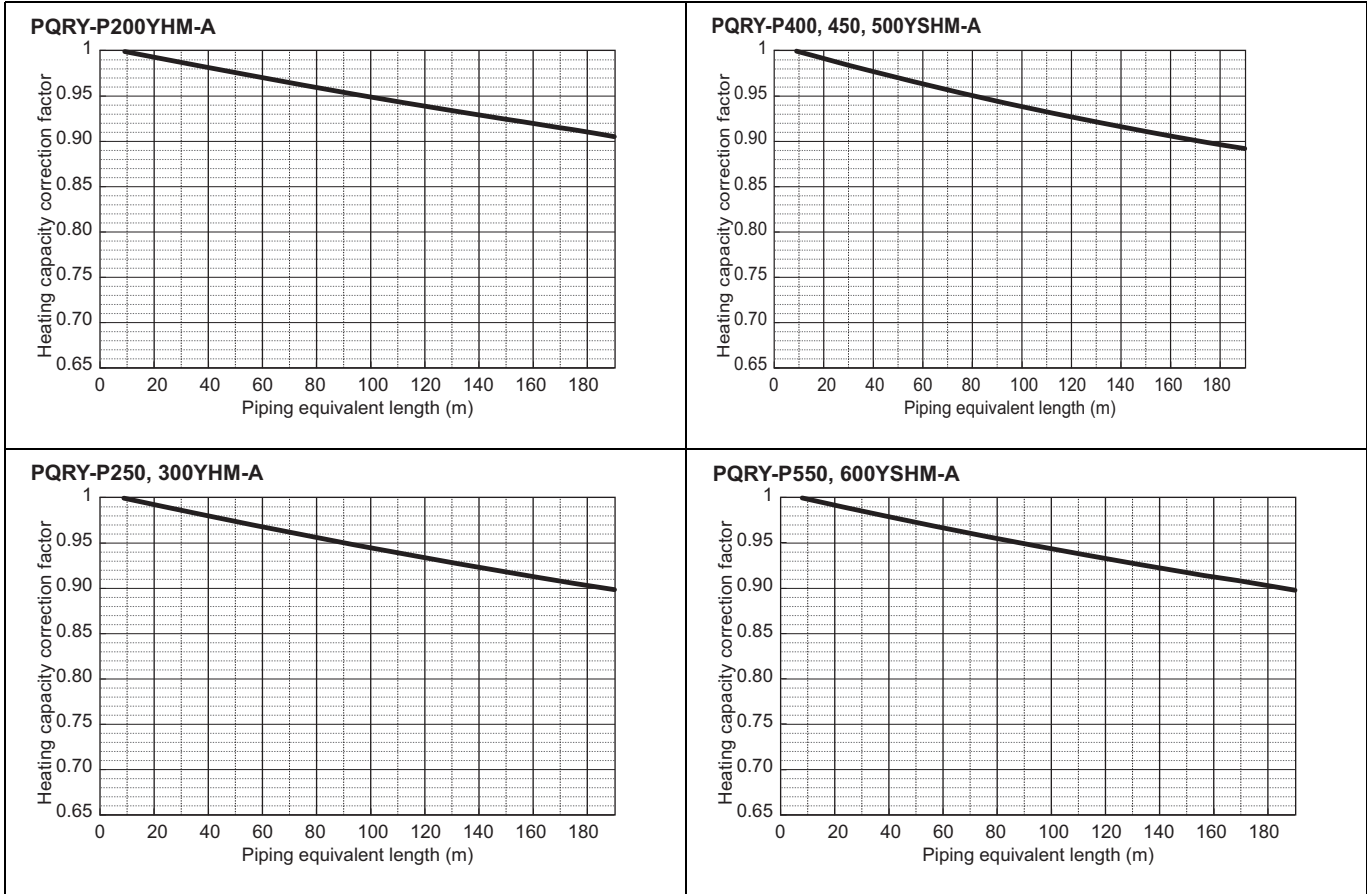

6-3-3. How to obtain the equivalent piping length

WR2

- 1 **PQRY-P200YHM**
Equivalent length = (Actual piping length to the farthest indoor unit) + (0.35 x number of bends in the piping) m
- 2 **PQRY-P250, 300YHM**
Equivalent length = (Actual piping length to the farthest indoor unit) + (0.42 x number of bends in the piping) m
- 3 **PQRY-P400, 450, 500, 550, 600YSHM**
Equivalent length = (Actual piping length to the farthest indoor unit) + (0.50 x number of bends in the piping) m

6-4. Correction by port counts of the BC controller

Indoor unit sizes P200 and P250 must be connected to 2 ports on the BC controller.
 Indoor unit sizes from P100 to P140 should normally be connected to 2 ports on the BC controller (set BC controller DIP-SW 4-6 to its ON position).
 In cases whereby indoor unit sizes from P100 to P140 are connected to only 1port on the BC controller (set BC controller DIP-SW 4-6 to its OFF position), the cooling capacity of the indoor unit should be multiplied by a correction factor of **0.97**.

6-5. Operation temperature range

• Cooling

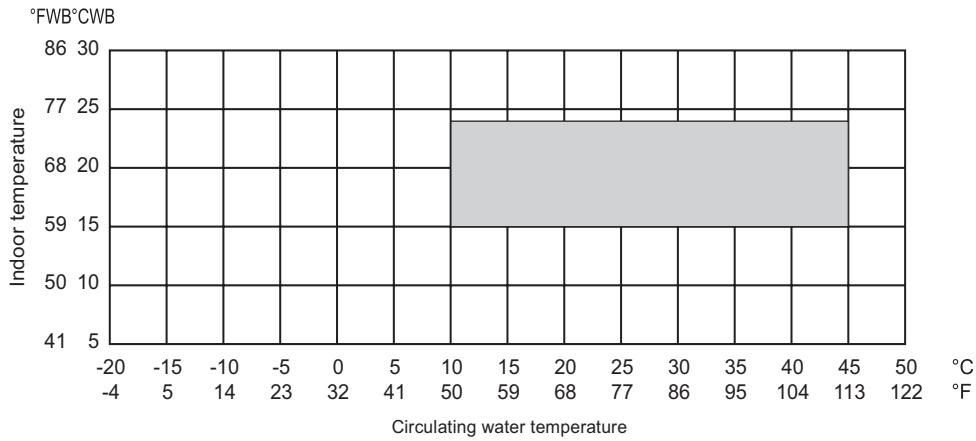

• Heating

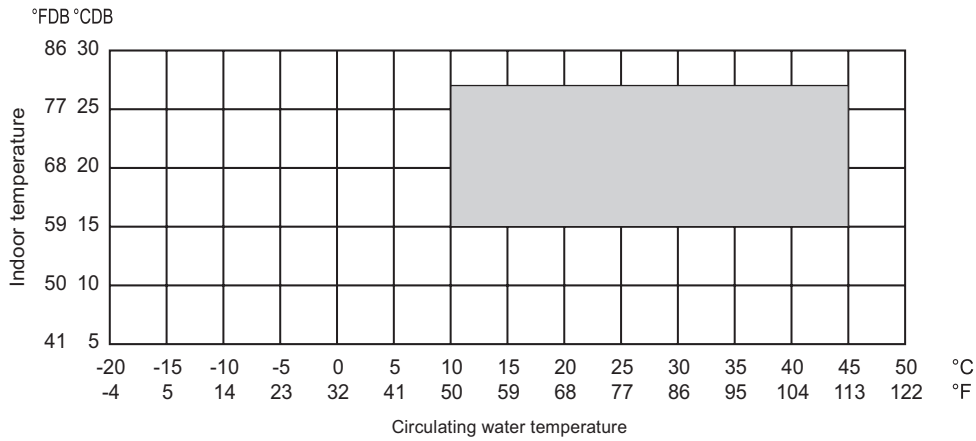

• Combination of cooling/heating operation (Cooling main or Heating main)

Water temperature	Indoor temperature	
	Cooling	Heating
10 to 45°C (50 to 113°F)	15 to 24°CWB (59 to 75°FWB)	15 to 27°CDB (59 to 81°FDB)

7-1. Designing of water circuit system

1) Example of basic water circuit

The water circuit of the water heat source CITY MULTI connects the heat source unit with the cooling tower/auxiliary heat source/heat storage tank/circulation pump with a single system water piping as shown in the figure below. The selector valve automatically controls to circulate water toward the cooling tower in the cooling season, while toward the heat storage tank in the heating season. If the circulation water temperature is kept in a range of 10~45°C[50~113°F]* regardless of the building load, the water heat source CITY MULTI can be operated for either cooling or heating. Therefore in the summer when only cooling load exists, the temperature rise of circulation water will be suppressed by operating the cooling tower. While in the winter when heating load increases, the temperature of circulation water may be dropped below 10°C[50°F]. Under such situation, the circulation water will be heated with the auxiliary heat source if it drops below a certain temperature. When the thermal balance between cooling and heating operation is in a correct proportion, the operation of the

auxiliary heat source and cooling tower is not required. In order to control the above thermal balance properly and use thermal energy effectively, utilizing of heat storage tanks, and night-time discounted electric power as an auxiliary heat source will be economical. Meantime as this system uses plural sets of heat source unit equipped with water heat exchangers, water quality control is important. Therefore it is recommended to use closed type cooling towers as much as possible to prevent the circulation water from being contaminated. When open type cooling towers are used, it is essential to provide proper maintenance control such as that to install water treatment system to prevent troubles caused by contaminated circulation water.

Example of basic water circuit for water heat source CITY MULTI

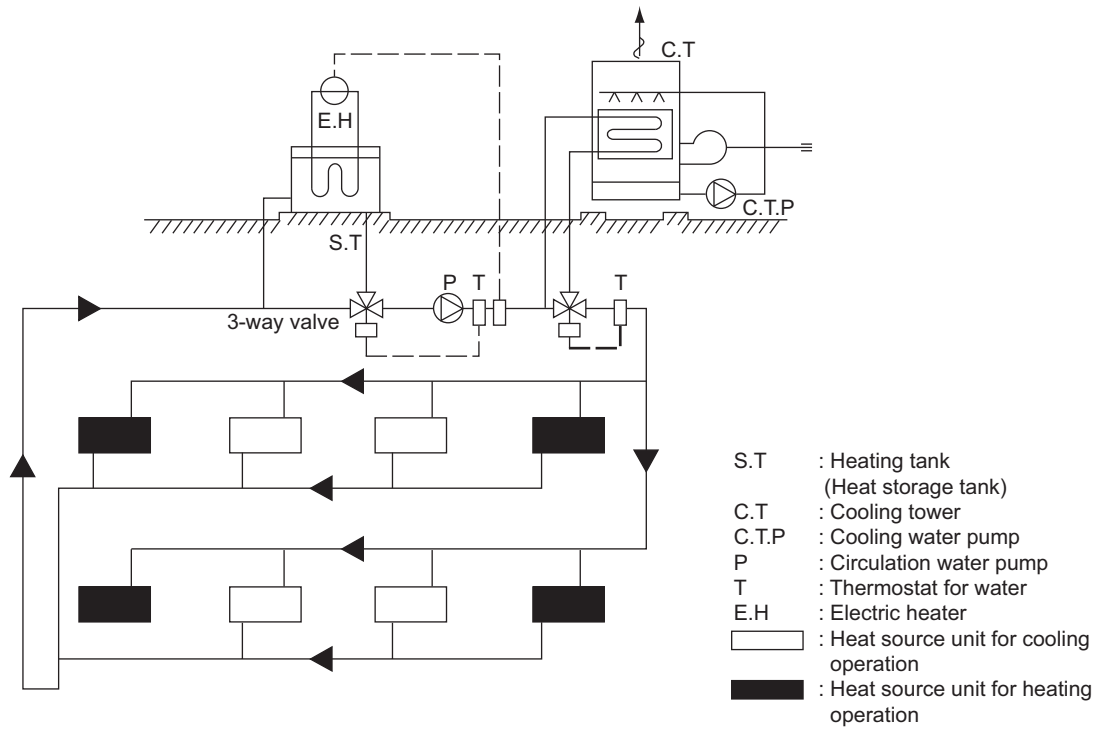

The indoor unit and refrigerant piping system are excluded in this figure.

WR2

2) Cooling tower

a) Types of cooling tower

The cooling towers presently used include the open type cooling tower, open type cooling tower + heat exchanger, closed type cooling tower, and air-cooled type cooling tower. However, as the quality control of circulation water is essential when units are installed in decentralized state inside a building, the closed type cooling tower is generally employed in such case.

Although the circulation water will not be contaminated by atmospheric air, it is recommended to periodically blow water inside the system and replenish fresh water instead.

In a district where the coil may be frozen in the winter, it is necessary to apply antifreeze solution to the circulation water, or take freeze protection measures such as to automatically discharge water inside the cooling coil at the stopping of the pump.

When the open type cooling tower is used, be sure to install a water quality control device in addition to the freeze protection measures, as the water may be deteriorated by atmospheric contaminants entered into the cooling tower and dissolved into the circulation water.

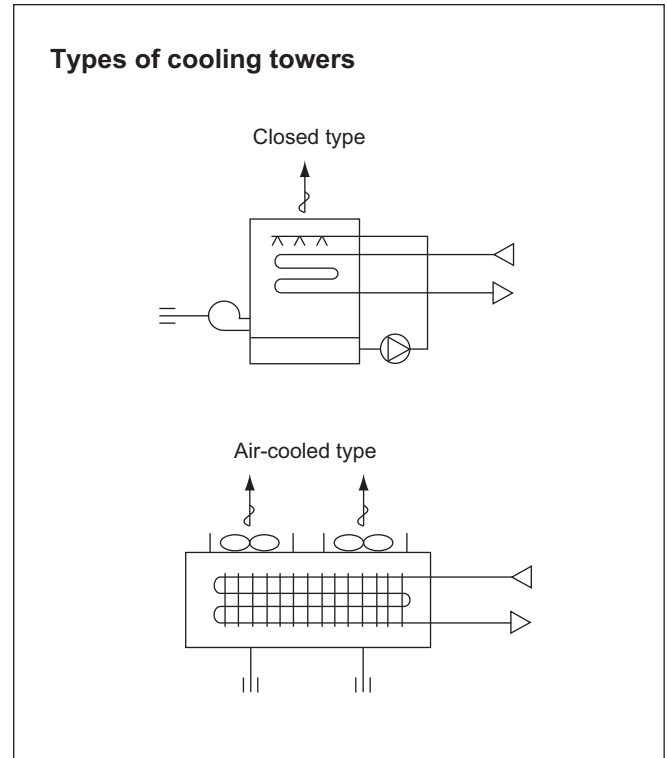

b) Calculation method of cooling tower capacity

All units of the water heat source CITY MULTI may possibly be in cooling operation temporarily (at pulling down) in the summer, however, it is not necessary to determine the capacity according to the total cooling capacity of all CITY MULTI units as this system has a wide operating water temperature range.

It is determined in accordance with the value obtained by adding the maximum cooling load of an actual building, the input heat equivalent value of all CITY MULTI units, and the cooling load of the circulating pumps. Please check for the values of the cooling water volume and circulation water volume.

$$\text{Cooling tower capacity} = \frac{Q_c + 860 \times (\Sigma Q_w + P_w)}{3,900} \text{ (Refrigeration ton)}$$

- Q_c : Maximum cooling load under actual state (kcal/h)
- Q_w : Total input of water heat source CITY MULTI at simultaneous operation under maximum state (kW)
- P_w : Shaft power of circulation pumps (kW)

$$\text{Cooling tower capacity} = \frac{Q_c + 3,412 \times (\Sigma Q_w + P_w)}{15,500} \text{ (Refrigeration ton)}$$

- Q_c : Maximum cooling load under actual state (BTU/h)
- Q_w : Total input of water heat source CITY MULTI at simultaneous operation under maximum state (kW)
- P_w : Shaft power of circulation pumps (kW)

* 1 Refrigerant ton of cooling tower capacity ≈ US refrigerant ton x (1+0.3)
= 3,900 kcal/h = 15,500 BTU/h

WR2

3) Auxiliary heat source and heat storage tank

When the heating load is larger than the cooling load, the circulation water temperature lowers in accordance with the heat balance of the system. It should be heated by the auxiliary heat source in order to keep the inlet water temperature within the operating range of the water heat source CITY MULTI.

Further in order to operate the water heat source CITY MULTI effectively, it is recommended to utilize the heat storage tank to cover the warming up load in the morning and the insufficient heat amount.

Effective heat utilization can be expected to cover insufficient heat at the warming up in the next morning or peak load time by storing heat by installing a heat storage tank or operating a low load auxiliary heat source at the stopping of the water heat source CITY MULTI. As it can also be possible to reduce the running cost through the heat storage by using the discounted night-time electric power, using both auxiliary heat source and heat storage tank together is recommended.

The effective temperature difference of an ordinary heat storage tank shows about 5deg. even with the storing temperature at 45°C[113°F].

However with the water heat source CITY MULTI, it can be utilized as heating heat source up to 15°C[59°F] with an effective temperature of a high 30deg°C[54deg°F]. approximately, thus the capacity of the heat storage tank can be minimized.

a) Auxiliary heat source

The following can be used as the auxiliary heat source.

- Boiler (Heavy oil, kerosine, gas, electricity)
- Electric heat (Insertion of electric heater into heat storage tank)
- Outdoor air (Air-heat source heat pump chiller)
- Warm discharge water (Exhaust water heat from machines inside building and hot water supply)
- Utilization of night-time lighting
- Solar heat

Please note that the auxiliary heat source should be selected after studying your operating environment and economical feasibility.

Determining the auxiliary heat source capacity

For the CITY MULTI water heat source system, a heat storage tank is recommended to use. When employment of the heat storage tank is difficult, the warming up operation should be arranged to cover the starting up heating load. Since the holding water inside the piping circuit owns heat capacity and the warming up operation can be assumed for about one hour except that in a cold region, the heat storage tank capacity is required to

be that at the maximum daily heating load including the warming up load at the next morning of the holiday. However the auxiliary heat source capacity should be determined by the daily heating load including warming up load on the week day.

For the load at the next morning of the holiday, heat storage is required by operating the auxiliary heat source even outside of the ordinary working hour.

When heat storage tank is not used

$$QH = HCT \left(1 - \frac{1}{COP_h} \right) - 1000 \times Vw \times \Delta T - 860 \times Pw$$

- QH : Auxiliary heat source capacity (kcal/h)
- HCT : Total heating capacity of each water heat source CITY MULTI (kcal/h)
- COP_H : COP of water heat source CITY MULTI at heating
- Vw : Holding water volume inside piping (m³)
- ΔT : Allowable water temperature drop = T_{WH} - T_{WL} (°C)
- T_{WH} : Heat source water temperature at high temperature side (°C)
- T_{WL} : Heat source water temperature at low temperature side (°C)
- Pw : Heat source water pump shaft power (kW)

$$QH = HCT \left(1 - \frac{1}{COP_h} \right) - 8.343 \times Vw \times \Delta T - 3412 \times Pw$$

- QH : Auxiliary heat source capacity (BTU/h)
- HCT : Total heating capacity of each water heat source CITY MULTI (BTU/h)
- COP_H : COP of water heat source CITY MULTI at heating
- Vw : Holding water volume inside piping (G)
- ΔT : Allowable water temperature drop = T_{WH} - T_{WL} (°F)
- T_{WH} : Heat source water temperature at high temperature side (°F)
- T_{WL} : Heat source water temperature at low temperature side (°F)
- Pw : Heat source water pump shaft power (kW)

WR2

When heat storage tank is not used

$$QH = \frac{HQ_{1T} \cdot \left(1 - \frac{1}{COP_h} \right) - 860 \times P_w \times T_2}{T_1} \times K \quad (\text{kcal})$$

- QH_{1T} : Total of heating load on weekday including warming up (kcal/day)
- T₁ : Operating hour of auxiliary heat source (h)
- T₂ : Operating hour of heat source water pump (h)
- K : Allowance factor (Heat storage tank, piping loss, etc.) 1.05~1.10

HQ_{1T} is calculated from the result of steady state load calculation similarly by using the equation below.
 HQ_{1T} = 1.15 x (ΣQ'a + ΣQ'b + ΣQ'c + ΣQ'd + ΣQ'f) T₂ - ψ (ΣQ'e₁ + ΣQ'e₂ + ΣQ'e₃) (T₂ - 1)

- Q'a : Thermal load from external wall/roof in each zone (kcal/h)
- Q'b : Thermal load from glass window in each zone (kcal/h)
- Q'c : Thermal load from partition/ceiling/floor in each zone (kcal/h)
- Q'd : Thermal load by infiltration in each zone (kcal/h)
- Q'f : Fresh outdoor air load in each zone (kcal/h)
- Q'e₁ : Thermal load from human body in each zone (kcal/h)
- Q'e₂ : Thermal load from lighting fixture in each zone (kcal/h)
- Q'e₃ : Thermal load from equipment in each zone (kcal/h)
- ψ : Radiation load rate 0.6~0.8
- T₂ : Air conditioning hour

$$QH = \frac{HQ_{1T} \cdot \left(1 - \frac{1}{COP_h} \right) - 3,412 \times P_w \times T_2}{T_1} \times K \quad (\text{BTU})$$

- QH_{1T} : Total of heating load on weekday including warming up (BTU/day)
- T₁ : Operating hour of auxiliary heat source (h)
- T₂ : Operating hour of heat source water pump (h)
- K : Allowance factor (Heat storage tank, piping loss, etc.) 1.05~1.10

HQ_{1T} is calculated from the result of steady state load calculation similarly by using the equation below.
 HQ_{1T} = 1.15 x (ΣQ'a + ΣQ'b + ΣQ'c + ΣQ'd + ΣQ'f) T₂ - ψ (ΣQ'e₁ + ΣQ'e₂ + ΣQ'e₃) (T₂ - 1)

- Q'a : Thermal load from external wall/roof in each zone (BTU/h)
- Q'b : Thermal load from glass window in each zone (BTU/h)
- Q'c : Thermal load from partition/ceiling/floor in each zone (BTU/h)
- Q'd : Thermal load by infiltration in each zone (BTU/h)
- Q'f : Fresh outdoor air load in each zone (BTU/h)
- Q'e₁ : Thermal load from human body in each zone (BTU/h)
- Q'e₂ : Thermal load from lighting fixture in each zone (BTU/h)
- Q'e₃ : Thermal load from equipment in each zone (BTU/h)
- ψ : Radiation load rate 0.6~0.8
- T₂ : Air conditioning hour

b) Heat storage tank

Heat storage tank can be classified by types into the open type heat storage tank exposed to atmosphere, and the closed type heat storage tank with structure separated from atmosphere. Although the size of the tank and its installation place should be taken into account, the closed type tank is being usually employed

by considering corrosion problems.

The capacity of heat storage tanks is determined in accordance with the daily maximum heating load that includes warming up load to be applied for the day after the holiday.

When auxiliary heat source is operated during operation and even after stopping of water heat source CITY MULTI unit

$$V = \frac{HQ_{2T} \left(1 - \frac{1}{COP_h} \right) - 860 \times P_w \times T_2 - Q_H \times T_2}{\Delta T \times 1,000 \times \eta V} \quad (\text{ton})$$

HQ_{2T} : Maximum heating load including load required for the day after the holiday (kcal/day)
 ΔT : Temperature difference utilized by heat storage tank (deg°C)
 ηV : Heat storage tank efficiency

$$HQ_{2T} : 1.3 \times (\Sigma Q'a + \Sigma Q'c + \Sigma Q'd + \Sigma Q'f) T_2 - \psi(\Sigma Qe2 + \Sigma Qe3) (T_2 - 1)$$

$$V = \frac{HQ_{2T} \left(1 - \frac{1}{COP_h} \right) - 3,412 \times P_w \times T_2 - Q_H \times T_2}{\Delta T \times \eta V} \quad (\text{lbs})$$

HQ_{2T} : Maximum heating load including load required for the day after the holiday (BTU/day)
 ΔT : Temperature difference utilized by heat storage tank (deg°F)
 ηV : Heat storage tank efficiency

$$HQ_{2T} : 1.3 \times (\Sigma Q'a + \Sigma Q'c + \Sigma Q'd + \Sigma Q'f) T_2 - \psi(\Sigma Qe2 + \Sigma Qe3) (T_2 - 1)$$

When auxiliary heat source is operated after stopping of water heat source CITY MULTI unit

$$V = \frac{HQ_{2T} \left(1 - \frac{1}{COP_h} \right) - 860 \times P_w \times T_2}{\Delta T \times 1,000 \times \eta V} \quad (\text{ton})$$

HQ_{2T} : Maximum heating load including load required for the day after the holiday (kcal/day)
 ΔT : Temperature difference utilized by heat storage tank (deg°C)
 ηV : Heat storage tank efficiency

$$HQ_{2T} : 1.3 \times (\Sigma Q'a + \Sigma Q'c + \Sigma Q'd + \Sigma Q'f) T_2 - \psi(\Sigma Qe2 + \Sigma Qe3) (T_2 - 1)$$

$$V = \frac{HQ_{2T} \left(1 - \frac{1}{COP_h} \right) - 3,412 \times P_w \times T_2}{\Delta T \times \eta V} \quad (\text{lbs})$$

HQ_{2T} : Maximum heating load including load required for the day after the holiday (BTU/day)
 ΔT : Temperature difference utilized by heat storage tank (deg°F)
 ηV : Heat storage tank efficiency

$$HQ_{2T} : 1.3 \times (\Sigma Q'a + \Sigma Q'c + \Sigma Q'd + \Sigma Q'f) T_2 - \psi(\Sigma Qe2 + \Sigma Qe3) (T_2 - 1)$$

WR2

4) Piping system

The following items should be kept in your mind in planning / designing water circuits.

- a) All units should be constituted in a single circuit in principle.
- b) When plural numbers of the water heat source CITY MULTI unit are installed, the rated circulating water flow rate should be kept by making the piping resistance to each unit almost same value. As an example, the reverse return system as shown below may be employed.
- c) Depending on the structure of a building, the water circuit may be prefabricated by making the layout uniform.
- d) When a closed type piping circuit is constructed, install an expansion tank usable commonly for a make-up water tank to absorb the expansion/contraction of water caused

by temperature fluctuation.

- e) If the operating temperature range of circulation water stays within the temperature near the normal temperature (summer : 29.4°C[85°F], winter : 21.1°C[70°F]), thermal insulation or anti-sweating work is not required for the piping inside buildings.

In case of the conditions below, however, thermal insulation is required.

- When well water is used for heat source water.
- When piped to outdoor or a place where freezing may be caused.
- When vapor condensation may be generated on piping due to an increase in dry bulb temperature caused by the entry of fresh outdoor air.

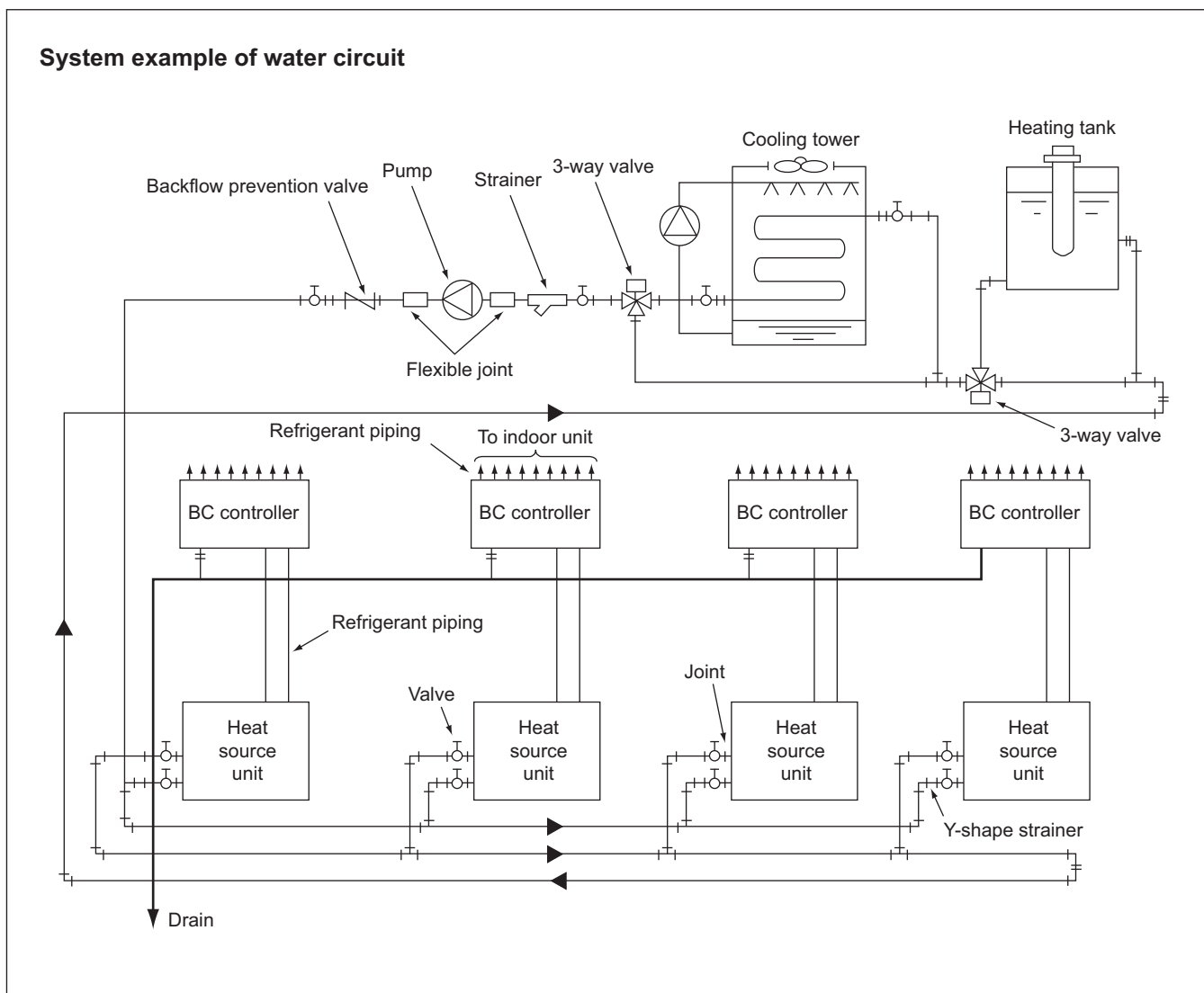

WR2

5) Practical System Examples and Circulation Water Control

Since the water heat source CITY MULTI is of water heat source system, versatile systems can be constituted by combining it with various heat sources. The practical system examples are given below. Either cooling or heating operation can be performed if the circulation water temperature of the water heat source CITY MULTI stays within a range of 15~45°C

[59~113°F]. However, the circulation water temperature near 32°C[90°F] for cooling and 20°C[68°F] for heating is recommended by taking the life, power consumption and capacity of the air conditioning units into consideration. The detail of the control is also shown below.

Example-1 Combination of closed type cooling tower and hot water heat storage tank (using underground hollow slab)

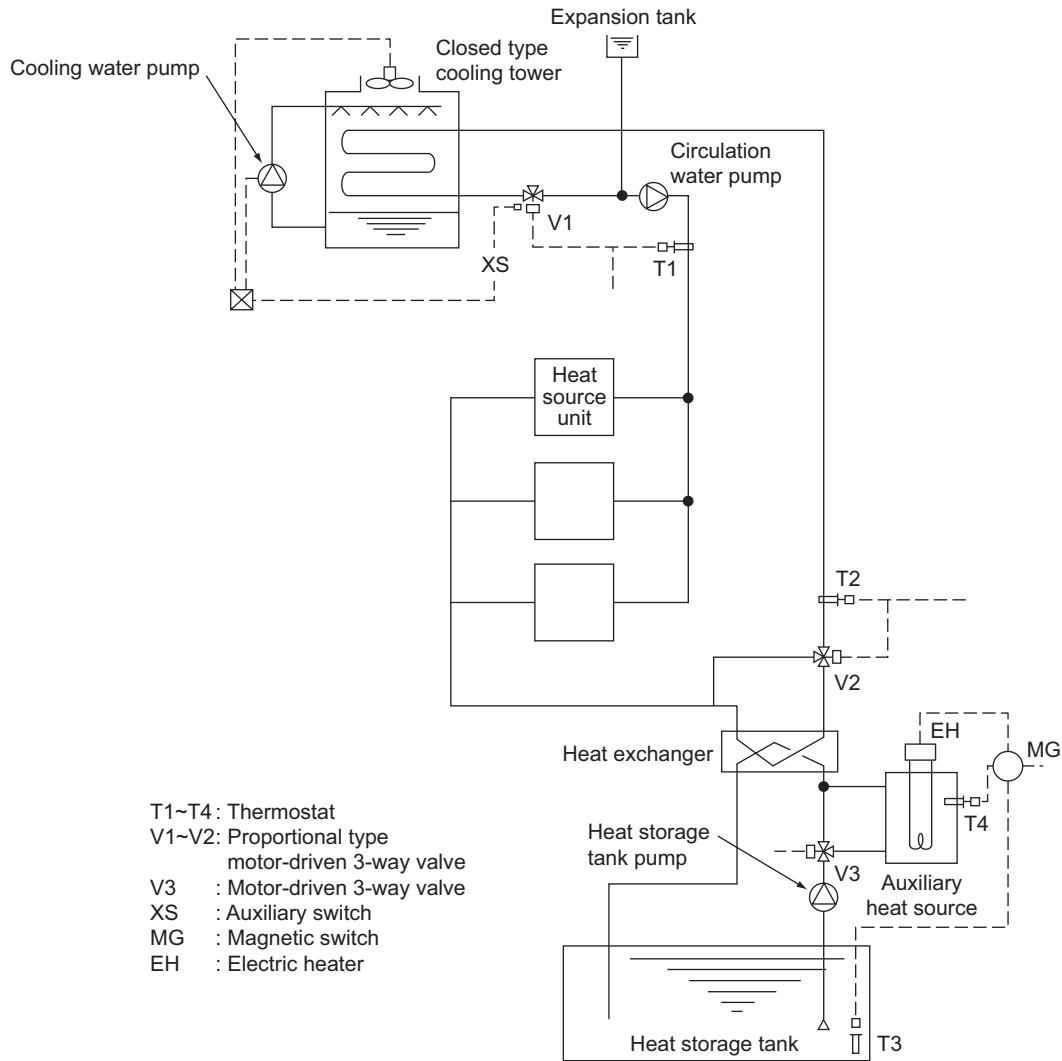

By detecting the circulation water temperature of the water heat source CITY MULTI system with T1 (around 32°C[90°F]) and T2 (around 20°C[68°F]), the temperature will be controlled by opening/closing V1 in the summer and V2 in the winter.

In the summer, as the circulation water temperature rises exceeding the set temperature of T1, the bypass port of V1 will open to lower the circulation water temperature. While in the winter, as the circulation water temperature drops, V2 will open following the command of T2 to rise the circulation water temperature.

The water inside the heat storage tank will be heated by the auxiliary heat source by V3 being opened with timer operation in the night-time. The electric heater of the auxiliary heat source will be controlled by T3 and the timer. The start/stop control of the fan and pump of the closed type cooling tower is applied with the step control of the fan and pump following the command of the auxiliary switch XS of V1, that operates only the fan at the light load while the fan and pump at the maximum load thus controlling water temperature and saving motor power.

Example-2 Combination of closed type cooling tower and hot water heat storage tank

- T1 : Proportional type, insertion system thermostat
 T2 : Proportional type, insertion system thermostat
 T3 : Proportional type, insertion system thermostat
 V1 : Proportional type, motor-driven 3-way valve
 V2 : Proportional type, motor-driven 3-way valve
 XS : Auxiliary switch (Duplex switch type)
 SC : Step controller
 R : Relay
 MG : Magnetic

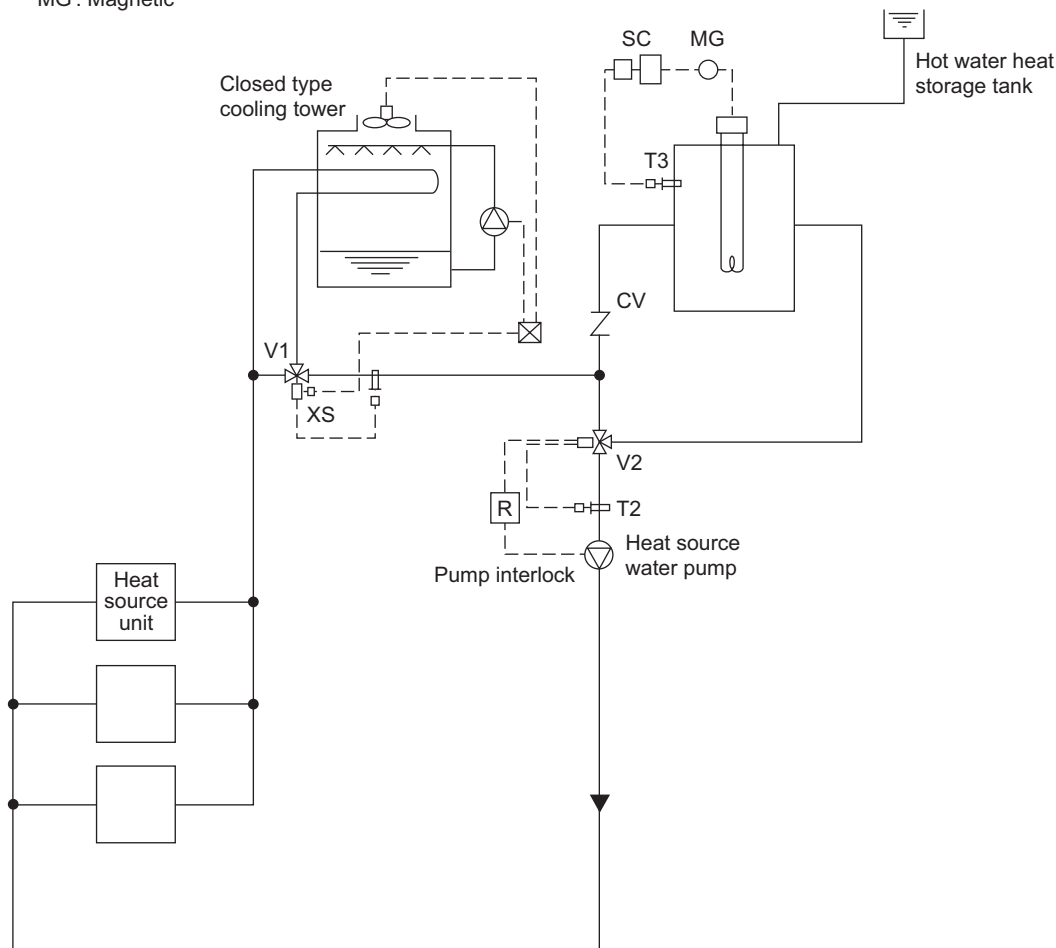

In the summer, as the circulation water temperature rises exceeding the set temperature of T1, the bypass port of V1 will open to lower the circulation water temperature. In the winter, if the circulation water temperature stays below 25°C[77°F], V2 will open/close by the command of T2 to keep the circulation water temperature constant.

The temperature of the hot water inside the heat storage tank will be controlled through the step control of the electric heater by step controller operation following the command of T3.

During the stopping of the heat source water pump, the bypass port of V2 will be closed fully by interlocking thus preventing the high temperature water from entering into the system at the starting of the pump.

The start/stop control of the fan and pump of the closed type cooling tower is applied with the step control of the fan and pump following the command of the auxiliary switch XS of V1, that operates only the fan at the light load while the fan and pump at the maximum load thus controlling water temperature and saving motor power.

Example-3 Combination of closed type cooling tower and boiler

- T1 : Proportional type, insertion system thermostat
 T2 : Proportional type, insertion system thermostat
 T3 : Proportional type, insertion system thermostat
 V1 : Proportional type, motor-driven 3-way valve
 S : Selector switch
 R : Relay
 XS : Auxiliary switch (Duplex switch type)

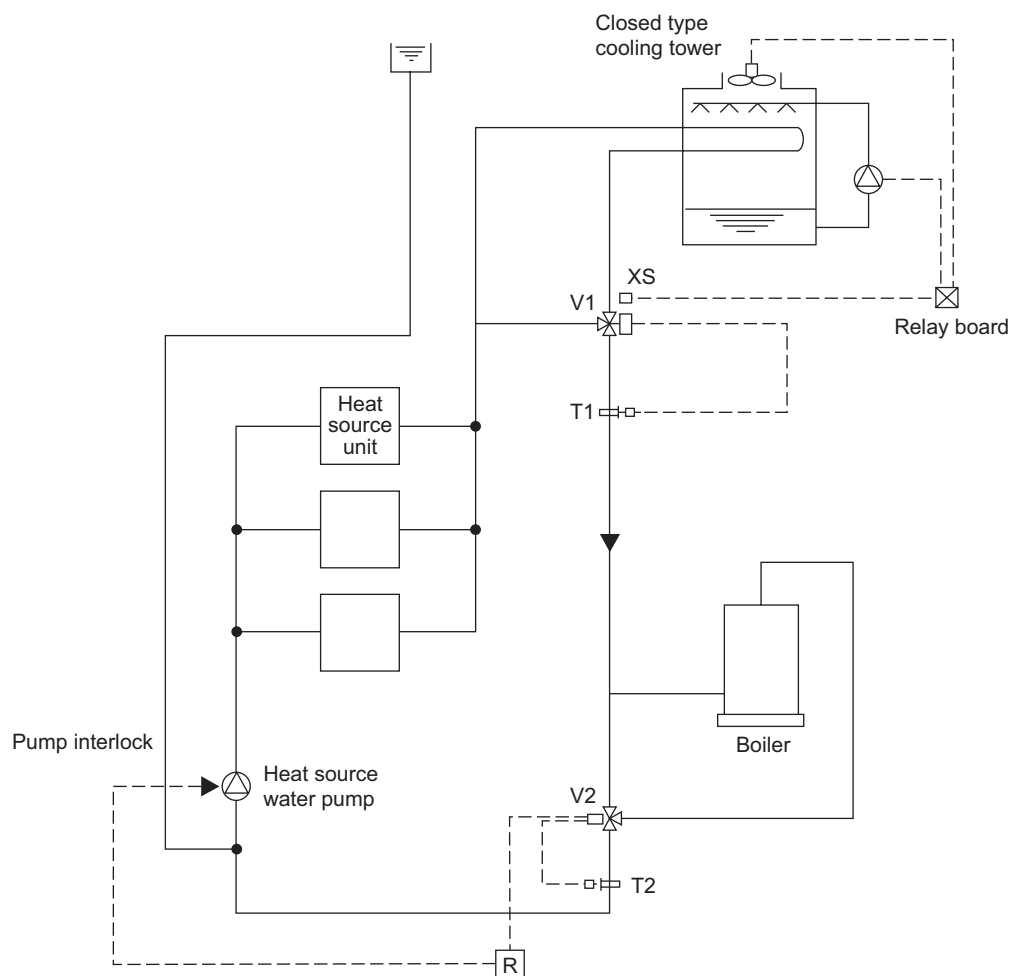

In the summer, as the circulation water temperature rises exceeding the set temperature of T1, the bypass port of V1 will close to lower the circulation water temperature. In the winter, if the circulation water temperature drops below 25°C[77°F], V2 will conduct water temperature control to keep the circulation water temperature constant. During the stopping of the heat source water pump, the bypass port of V2 will be closed fully by interlocking. The start/stop control of the fan and pump of the closed type cooling tower is applied with the step control following the command of the auxiliary switch XS of V1, thus controlling water temperature and saving motor power.

Example-4 Combination of closed type cooling tower and heat exchanger (of other heat source)

- T1 : Proportional type, insertion system thermostat
 T2 : Proportional type, insertion system thermostat
 V1 : Proportional type, motor-driven 3-way valve
 V2 : Proportional type, motor-driven 3-way valve
 S : Selector switch
 R : Relay
 XS : Auxiliary switch (Duplex switch type)

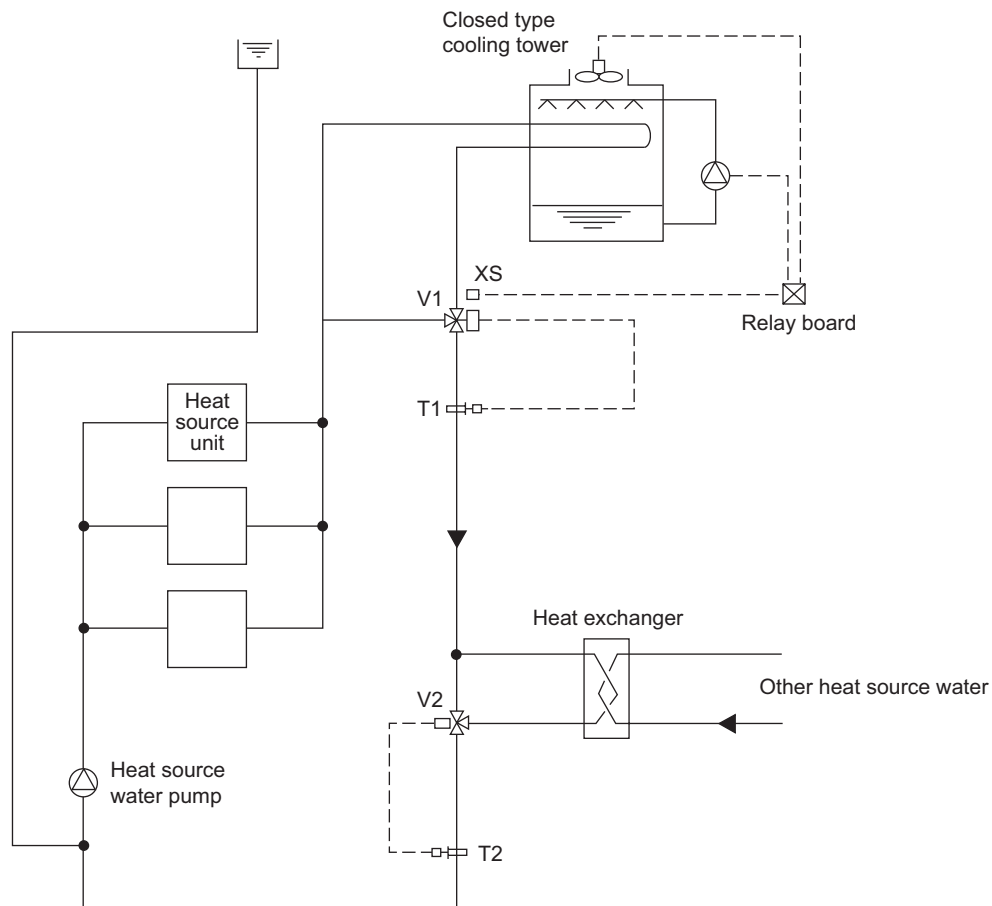

In the summer, as the circulation water temperature rises exceeding the set temperature of T1, the bypass port of V1 will close to lower the circulation water temperature. In the winter, if the circulation water temperature drops below 26°C[79°F], V2 will conduct water temperature control to keep the circulation water temperature constant. During the stopping of the heat source water pump, the bypass port of V2 will be closed fully by interlocking. The start/stop control of the fan and pump of the closed type cooling tower is applied with the step control following the command of the auxiliary switch XS of V1, thus controlling water temperature and saving motor power.

6) Pump interlock circuit

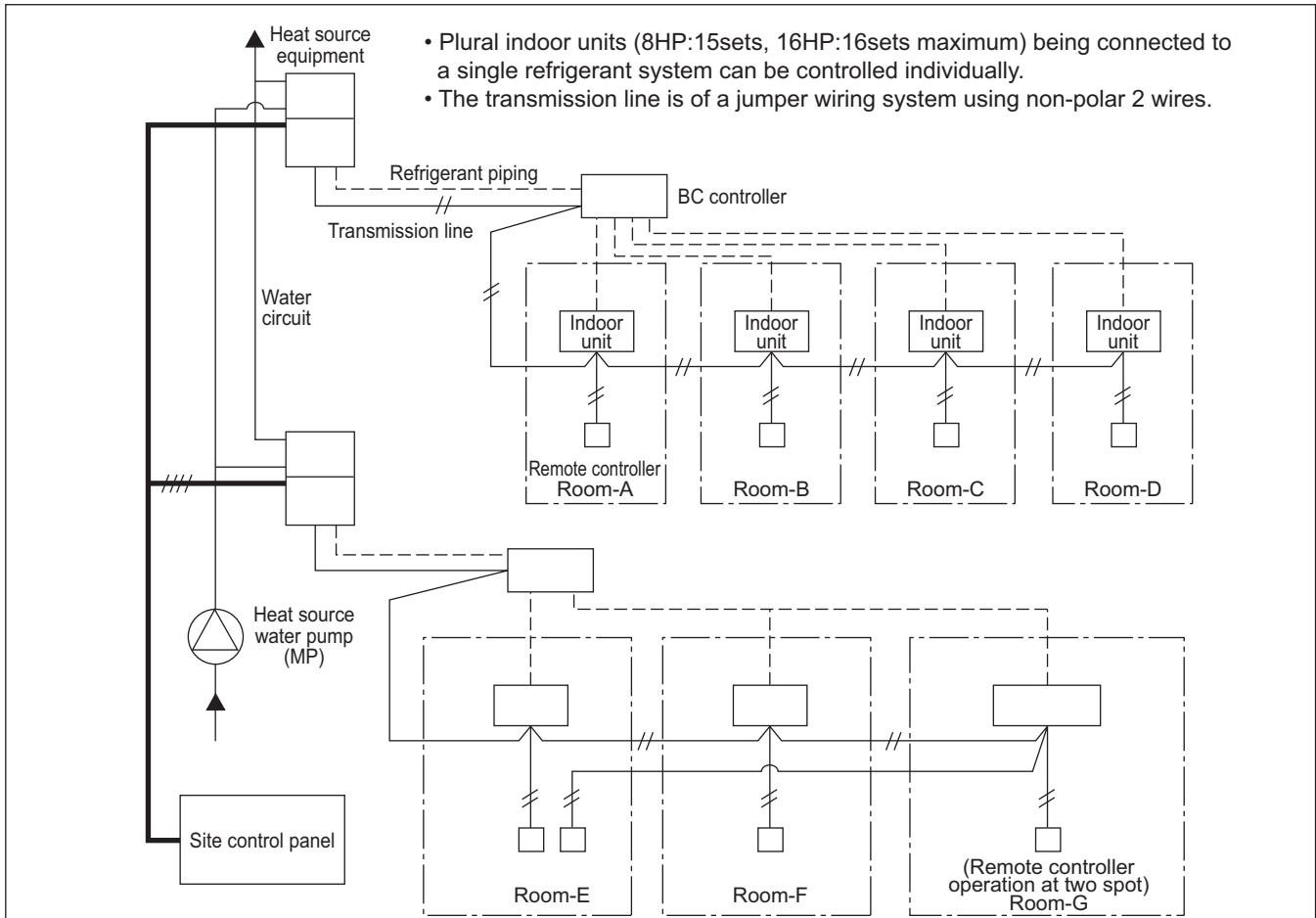

Wiring diagram

This circuit uses the "Terminal block for pump interlock (TB8)" inside the electrical parts box of the heat source equipment. This circuit is for interlocking the heat source equipment operation and the heat source water pump.

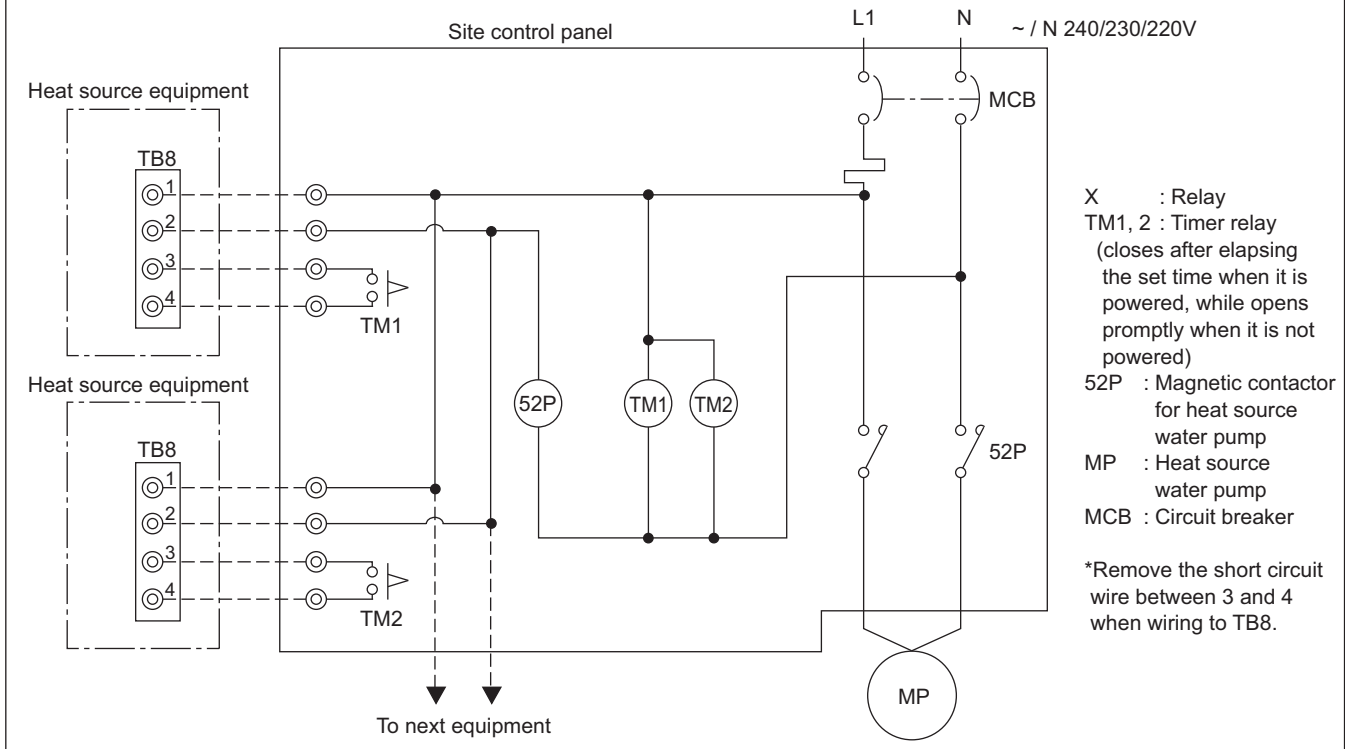

WR2

Operation ON signal

Terminal No.	TB8-1, 2
Output	Relay contacts output Rated voltage : L1 - N : 220 ~ 240V Rated load : 1A
Operation	<ul style="list-style-type: none"> • When Dip switch 2-7 is OFF The relay closes during compressor operation. • When DIP switch 2-7 is ON. The relay closes during reception of cooling or the heating operation signal from the controller. (Note : It is output even if the thermostat is OFF (when the compressor is stopped).)

Pump Interlock

Terminal No.	TB8-3, 4
Input	Level signal
Operation	If the circuit between TB8-3 and TB8-4 is open, compressor operation is prohibited.

WR2

7-2. Water piping work

Although the water piping for the CITY MULTI WR2 system does not differ from that for ordinary air conditioning systems, pay special attention to the items below in conducting the piping work.

1) Items to be observed on installation work

- In order to equalize piping resistance for each unit, adapt the reverse return system.
- Mount a joint and a valve onto the water outlet/inlet of the unit to allow for maintenance, inspection and replacement work. Be sure to mount a strainer at the water inlet piping of the unit. (The strainer is required at the circulation water inlet to protect the heat source unit.)
- * The installation example of the heat source unit is shown right.
- Be sure to provide an air relief opening on the water piping properly, and purge air after feeding water to the piping system.
- Condensate will generate at the low temperature part inside the heat source equipment. Connect drain piping to the drain piping connection located at the bottom of the heat source equipment to discharge it outside the equipment.
- At the center of the header of the heat exchanger water inlet inside the unit, a plug for water discharge is being provided.
Use it for maintenance work or the like.
- Mount a backflow prevention valve and a flexible joint for vibration control onto the pump.
- Provide a sleeve to the penetrating parts of the wall to prevent the piping.
- Fasten the piping with metal fitting, arrange the piping not to expose to cutting or bending force, and pay sufficient care for possible vibration.
- Be careful not to erroneously judge the position of the inlet and outlet of water.
(Lower position : Inlet, Upper position : Outlet)
- When connecting heat source unit water piping and water piping on site, apply liquid sealing material for water piping over the sealing tape before connection. (for Maximum water pressure above 1.0MPa)
- Wrap the sealing tape as follows.
 - ① Wrap the joint with sealing tape in the direction of the threads (clockwise), and do not let the tape run over the edge.
 - ② Overlap the sealing tape by two-thirds to three-fourths of its width on each turn. Press the tape with your fingers so that it is pressed firmly against each thread.
 - ③ Leave the 1.5th through 2nd farthest threads away from the pipe end unwrapped.
- Hold the pipe on the unit side in place with a spanner when installing the pipes or strainer. Tighten screws to a torque of 150N·m.

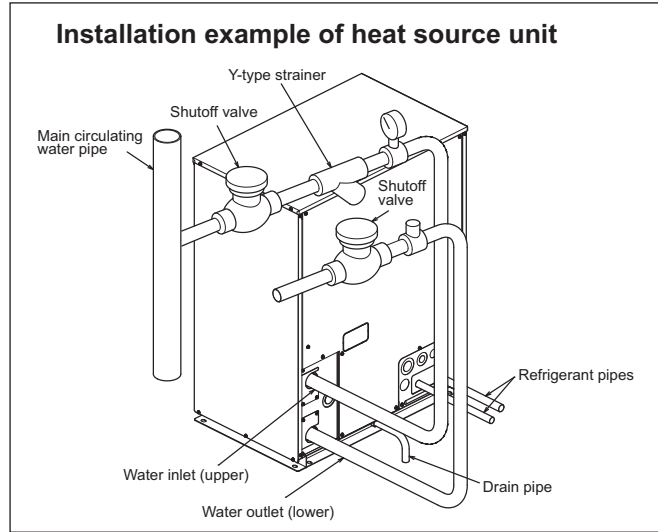

3) Water treatment and water quality control

For the circulation water cooling tower of the CITY MULTI WR2 system, employment of the closed type is recommended to keep water quality. However, in the case that an open type cooling tower is employed or the circulating water quality is inferior, scale will adhere onto the water heat exchanger leading to the decreased heat exchange capacity or the corrosion of the heat exchanger. Be sufficiently careful for water quality control and water treatment at the installation of the circulation water system

- Removal of impurities inside piping
Be careful not to allow impurities such as welding fragment, remaining sealing material and rust from mixing into the piping during installation work.
- Water treatment
The water quality standards have been established by the industry (Japan Refrigeration, Air Conditioning Industry Association, in case of Japan) for water treatment to be applied.

2) Thermal insulation work

Thermal insulation or anti sweating work is not required for the piping inside buildings in the case of the CITY MULTI WR2 system if the operating temperature range of circulation water stays within the temperature near the normal (summer : 29.4°C[85°F], winter : 21.1°C[70°F]). In case of the conditions below, however, thermal insulation is required.

- Use of well water for heat source water
- Outdoor piping portions
- Indoor piping portions where freezing may be caused in winter
- A place where vapor condensation may be generated on piping due to an increase in dry bulb temperature inside the ceiling caused by the entry of fresh outdoor air
- Drain piping portions

Items	Lower mid-range temperature water system		Tendency	
	Recirculating water [20<T<60°C] [68<T<140°F]	Make-up water	Corrosive	Scale-forming
pH (25°C[77°F])	7.0 ~ 8.0	7.0 ~ 8.0	○	○
Electric conductivity (mS/m) (25°C[77°F])	30 or less	30 or less	○	○
(μS/cm) (25°C[77°F])	[300 or less]	[300 or less]		
Chloride ion (mg Cl/l)	50 or less	50 or less	○	
Sulfate ion (mg SO ₄ ²⁻ /l)	50 or less	50 or less	○	
Acid consumption (pH4.8) (mg CaCO ₃ /l)	50 or less	50 or less		○
Total hardness (mg CaCO ₃ /l)	70 or less	70 or less		○
Calcium hardness (mg CaCO ₃ /l)	50 or less	50 or less		○
Ionic silica (mg SiO ₂ /l)	30 or less	30 or less		○
Iron (mg Fe/l)	1.0 or less	0.3 or less	○	○
Copper (mg Cu/l)	1.0 or less	0.1 or less	○	
Sulfide ion (mg S ²⁻ /l)	not to be detected	not to be detected	○	
Ammonium ion (mg NH ₄ ⁺ /l)	0.3 or less	0.1 or less	○	
Residual chlorine (mg Cl/l)	0.25 or less	0.3 or less	○	
Free carbon dioxide (mg CO ₂ /l)	0.4 or less	4.0 or less	○	
Ryzner stability index	-	-	○	○

Reference : Guideline of Water Quality for Refrigeration and Air Conditioning Equipment. (JRA GL02E-1994)

In order to keep the water quality within such standards, you are kindly requested to conduct bleeding-off by overflow and periodical water quality tests, and use inhibitors to suppress condensation or corrosion. Since piping may be corroded by some kinds of inhibitor, consult an appropriate water treatment expert for proper water treatment.

4) Pump interlock

Operating the heat source unit without circulation water inside the water piping can cause a trouble. Be sure to provide interlocking for the unit operation and water circuit. Since the terminal block is being provided inside the unit, use it as required.

8-1. JOINT

CITY MULTI units can be easily connected by using Joint sets and Header sets provided by Mitsubishi Electric. Three kinds of Joint sets are available for use. Refer to section 3 in "System Design" or the Installation Manual that comes with the Joint set for how to install the Joint set.

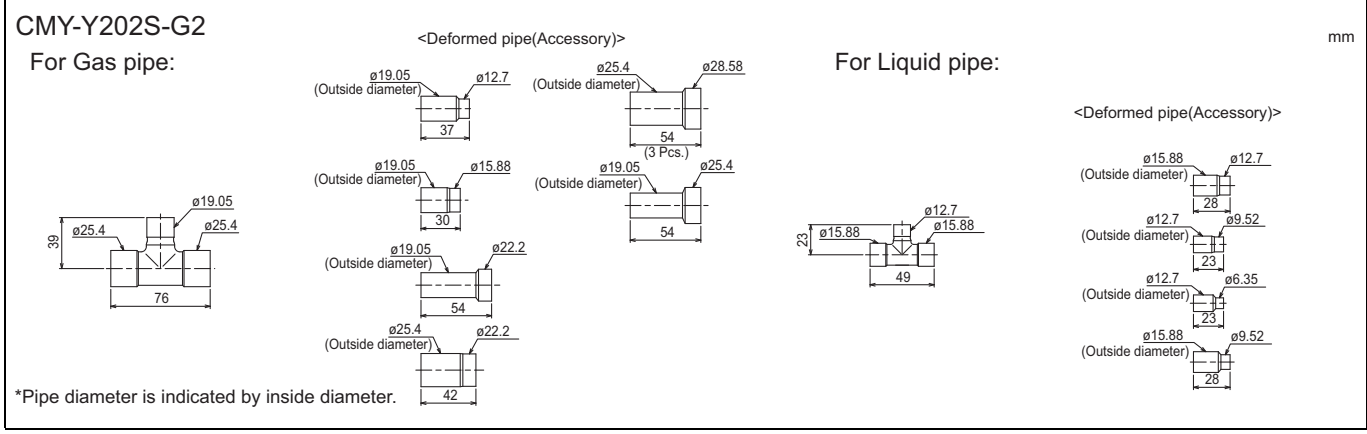
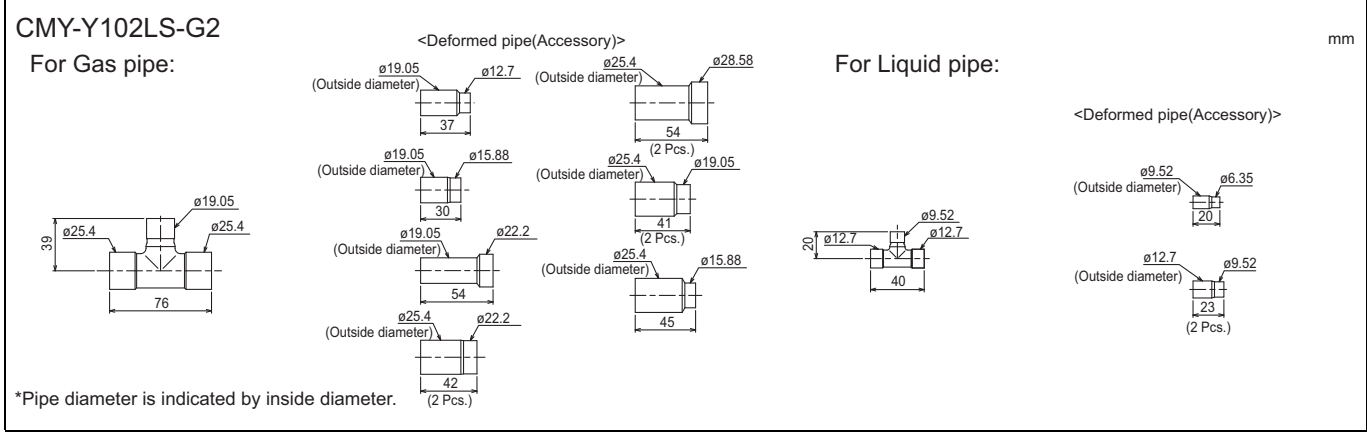
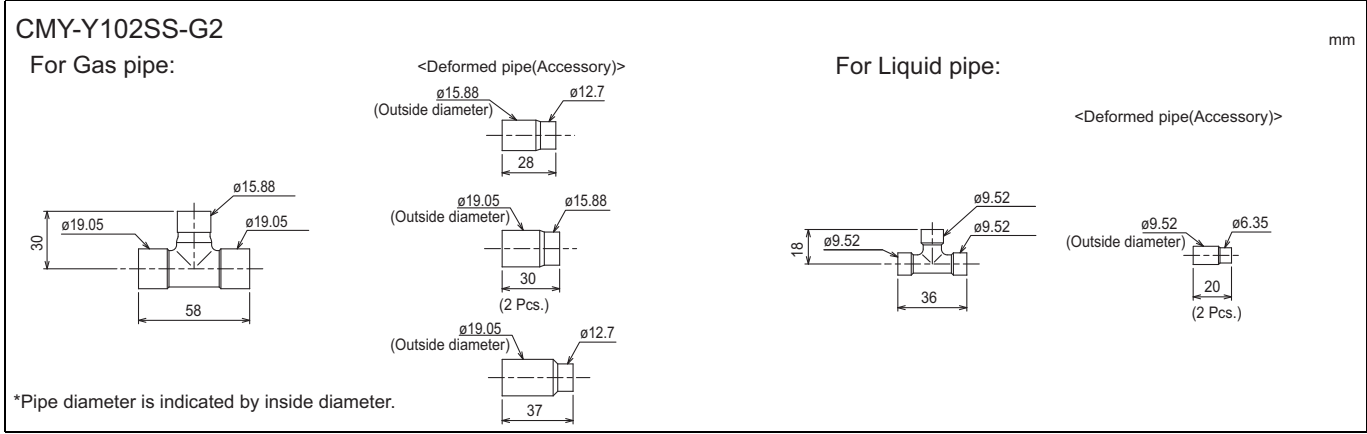

WR2

8-2. OUTDOOR TWINNING KIT

The following optional Outdoor Twinning Kit is needed to use to combine multiple refrigerant pipes. Refer to the chapter entitled System Design Section for the details of selecting a proper twinning kit.

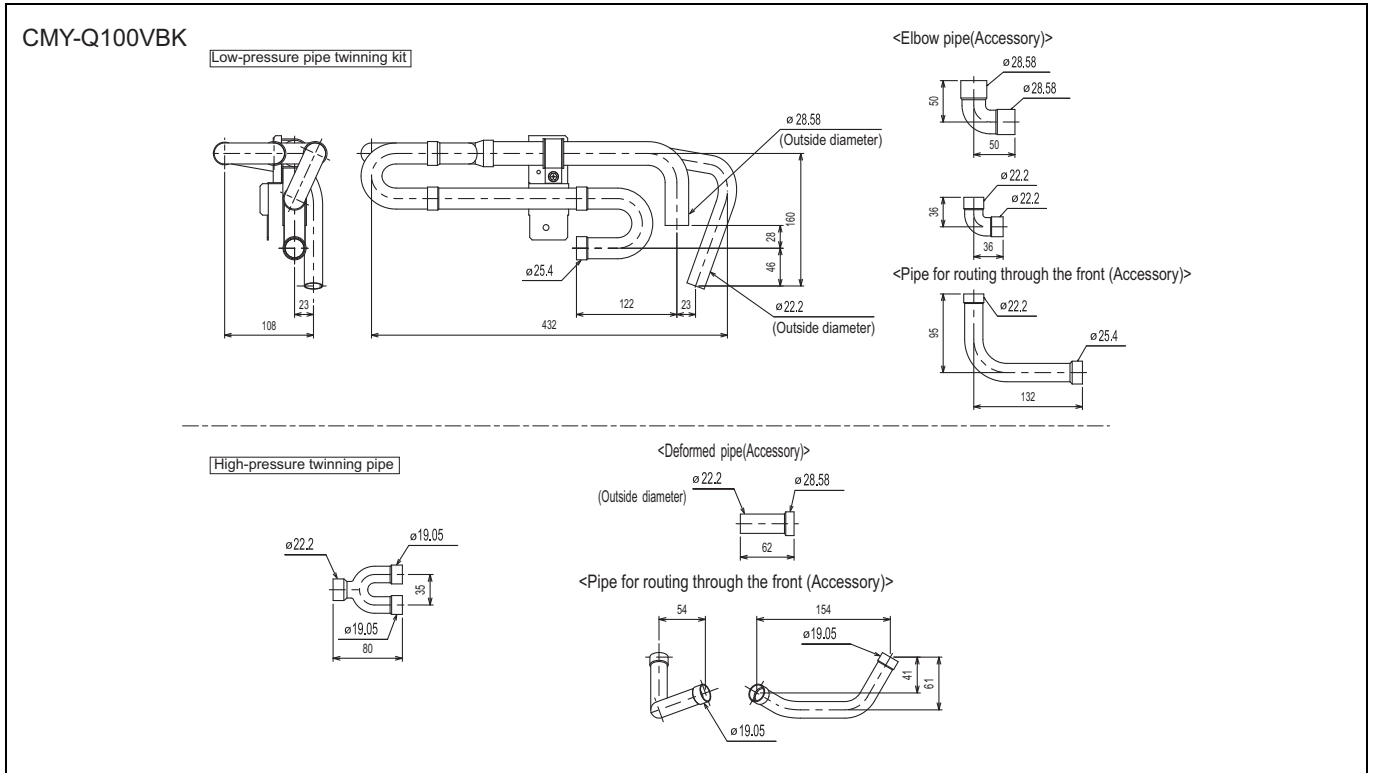

Note 1. Reference the attitude angle of the branch pipe below the fig.

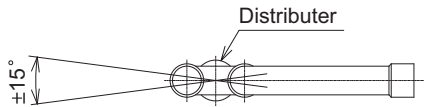

The angle of the branch pipe for high pressure is within $\pm 15^\circ$ against the horizontal plane.







2. Use the attached pipe to braze the port-opening of the distributor.
3. Pipe diameter is indicated by inside diameter.

WR2

8-3. JOINT KIT "CMY-R160-J1" FOR BC CONTROLLER

Joint kit "CMY-R160-J1" for BC controller is used to combine 2 ports of the BC controller at a PQR-Y-P-Y(S)HM-A system so as to enable down-stream Indoor capacity above P80 as shown in Fig. 1.

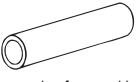
The Joint kit include following items:

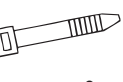
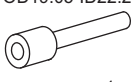
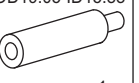
① Instruction	② Joint pipe (Small)	③ Joint pipe (Large)	④ Cover 1	⑤ Cover 2	⑥ Cover 3	⑦ Band	⑧ Reducer 1	⑨ Reducer 2
 This sheet 1pc	 1pc	 1pc	 2pcs	 1pc for gas side	 1pc for liquid side	 8pcs	 OD19.05-ID22.2 1pc	 OD19.05-ID15.88 1pc

Please prepare the following items in the field. ①Tape for insulation material sealing ②Extension pipe for refrigerant circuit Ref.: WT05840X01_01

② Joint pipe (for liquid side)

③ Joint pipe (for gas side)

mm(in.)

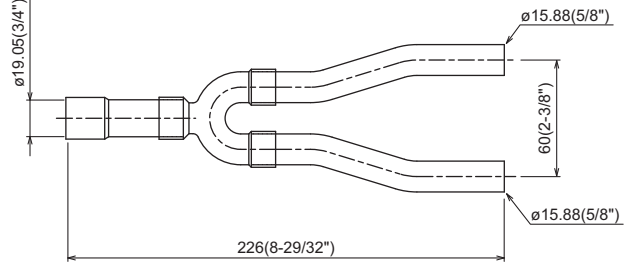
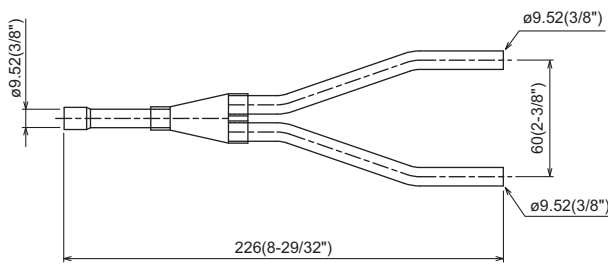

1. Designing CMY-R160-J1 to a PQR-Y-P-Y(S)HM-A system

The maximum down-stream Indoor capacity for 1 port of BC controller is P80. When the down-stream Indoor capacity is above P80, Joint kit CMY-R160-J1 is needed to combined 2 ports of BC controller to enlarge the capacity, like Group 2 and 3 in Fig. 1.

Maximum 3 Indoor units are allowed to connect to 1 port of BC controller or 2 combined ports of BC controller using CMY-R160-J1.

When connecting Indoor units to 1 port of BC controller or 2 combined ports of BC controller using CMY-R160-J1 or CMY-Y102SS-G2 is applicable, like Group 1 and 2 in Fig. 1

Caution: Mixed cooling and heating mode at the same time for Indoor units connecting to 1 port or 2 combined ports is not available.

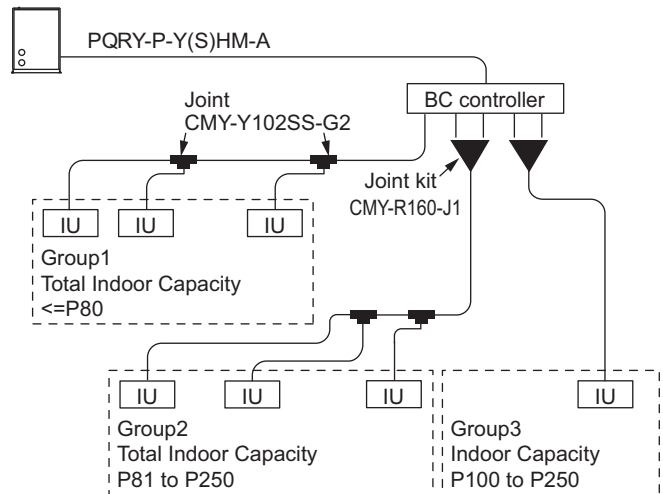

Fig.1. CMY-R160-J1 applying schera

Ref.: WT05840X01_02

2. Piping at the installation site

The connection of CMY-R160-J1 to BC controller and pipe leading to Indoor units is referable to Fig. 2. Non-oxidized brazing is necessary. All piping must be careful to avoid foreign material getting inside.

After piping and air-tight testing, insulation work to the Joint and pipe should be done. Details is available at the Installation Manual.

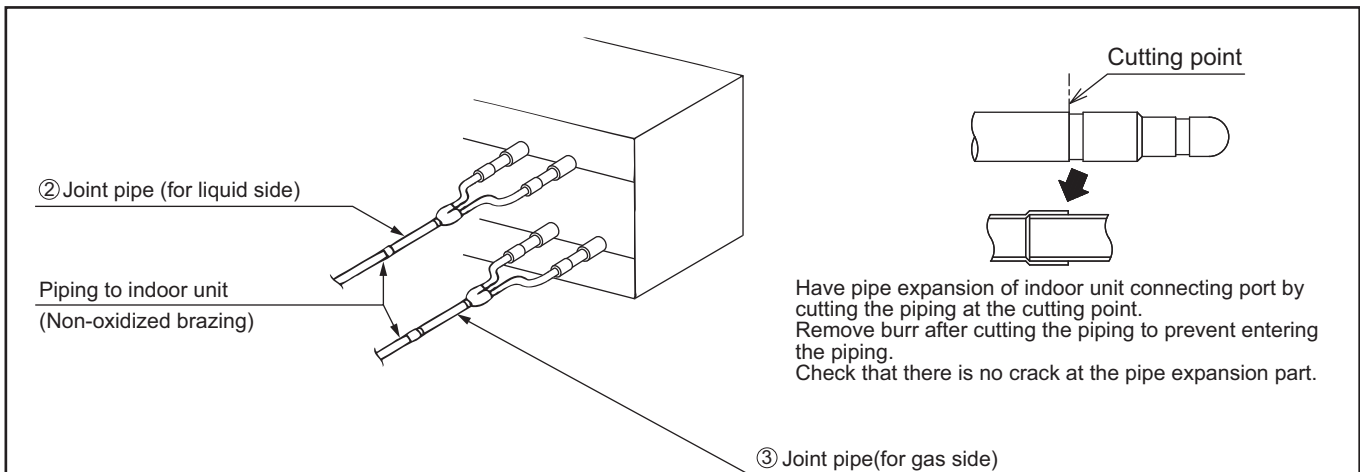

Fig.2. Connecting CMY-R160-J1

Ref.: WT05840X01_03

Ref: CMY_R160_J_DOC_EUDB

CITY MULTI

3. CONTROLLER

1. MITSUBISHI ELECTRIC's Air-conditioner Network System. (MELANS)	3 - 2
1-1.Function table of controllers	3 - 3
2. Local remote controller	3 - 4
2-1.MA remote controller [PAR-31MAA]	3 - 4
2-2.Smart ME Controller [PAR-U02MEDA]	3 - 5
2-3.Simple MA remote controller [PAC-YT52CRA]	3 - 6
2-4.Wireless remote controller [PAR-FL32MA / PAR-FA32MA / PAR-SA9FA / PAR-SL94B-E]	3 - 7
2-5.LOSSNAY remote controller [PZ-52SF]	3 - 8
2-6.LOSSNAY remote controller for LGH-RX5-E [PZ-60DR-E]	3 - 9
3. System remote controller	3 - 10
3-1.ON/OFF remote controller [PAC-YT40ANRA]	3 - 10
3-2.Advanced touch controller [AT-50B]	3 - 12
3-3.Centralized controller [AG-150A]	3 - 20
3-4.Centralized controller [EB-50GU-J]	3 - 29
3-5.Centralized controller [GB-50ADA-J]	3 - 37
3-6.Power supply unit [PAC-SC51KUA]	3 - 44
3-7.Expansion Controller [PAC-YG50ECA]	3 - 46
3-8.Integrated centralized control software [TG-2000A]	3 - 49
3-9.Electric amount count software [PAC-YG11CDA]	3 - 54
3-10.PLC software for general equipment [PAC-YG21CDA]	3 - 55
3-11.BACnet [®] interface [BAC-HD150]	3 - 56
3-12.PLC software for demand input [PAC-YG41CDA]	3 - 58
3-13.LONWORKS [®] interface [LMAP04-E]	3 - 60
3-14.Transmission booster [PAC-SF46EPA]	3 - 63
3-15.AHC ADAPTER [PAC-IF01AHC-J]	3 - 64
3-16.PI controller [PAC-YG60MCA]	3 - 69
3-17.DIDO controller [PAC-YG66DCA]	3 - 75
3-18.AI controller [PAC-YG63MCA]	3 - 85
4. System component	3 - 94
4-1.S, Y, HP, R2 series	3 - 94
4-2.Outdoor unit input/output connector	3 - 96
4-3.WY, WR2 series	3 - 98
4-4.Heat source unit input/output connector	3 - 100
4-5.Indoor unit "E" type input/output connector	3 - 101